

ADC Structured Cabling Solutions **10 Gig Solution** Unprecedented performance – unrivalled flexibility

10 Gig.



A 10 Gigabit Ethernet solution

as *unique* as your needs

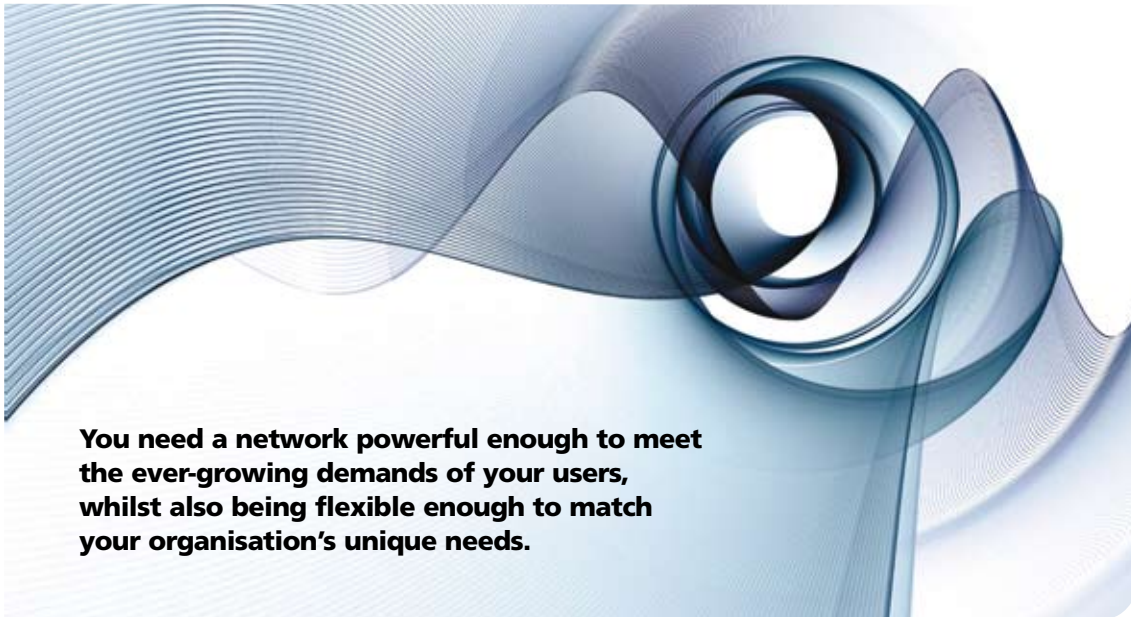

As the world's leading supplier in the 10 Gigabit Ethernet market, ADC can provide you with innovative connectivity technology to create your ideal network. We offer the full range of fibre, UTP and STP solutions, which means we can concentrate on finding the most relevant solution for you, rather than promoting one particular technology over another. This brochure gives you an overview of our comprehensive range of solutions, showing you how we can help you move to the next level of network sophistication.

Upgrading to 10 Gig is becoming essential

Every end user on your network is asking for more. More speed. More applications. More memory. More devices. Meanwhile, as processors and operating systems become ever more powerful, new applications and devices mean the network is becoming more and more crowded.

Eventually the equipment on your network will work quicker than the infrastructure that connects them, leading to bottlenecks and network latency. Any down time isn't just inconvenient for the end user; in a mission critical environment it could lose your organisation custom, reputation and revenue. The only way to make sure the infrastructure will never let you down is to migrate to a more powerful networking solution.

And that solution is 10 Gigabit Ethernet.

In this brochure:

Why 10 Gig? Page 2

Why ADC? Page 4

Unshielded, shielded, fibre? Page 6 - 11

Installation and beyond. Page 12 onwards

The time has come for a more powerful network

Most active network equipment, including computers, servers and switches, has a maximum useful life of 3 to 5 years. Cabling on the other hand has a useful life of 15 to 20 years. That means the cabling infrastructure you install, must be capable of supporting the increasing data speeds of at least three generations of hardware upgrades.

If you are planning a new network, now is the time to move to 10 Gig, ensuring your infrastructure can cope now and in the future. As new technologies develop over the coming years, you won't face the cost and inconvenience of having to take out the cabling and start again. At ADC, we have the heritage, expertise and innovative product range to help you stay ahead of the game and ensure you have the most future-proof network possible.

Why you should choose 10 Gig

- IP has converged on your network. Data, VoIP, remote access, intelligent buildings and other applications that are creating ever more demands on your network.
- Data Centres are storing and processing an ever-growing amount of data.
- Complying with ever increasing legislation means even greater network load.
- With thin client technology, the processing power of the desktop is migrating to the Data Centre, creating the need for greater network performance.
- Organisations are already securing competitive advantage by installing 10 Gig solutions.



"The Augmented Cat 6 solution has addressed the growth and expansion plans of the company. Due to its superior technology, our product development teams are now able to get better response times, better availability, and better performance.

Most importantly, since it eliminates the need for re-cabling in the future, we are able to get a better return on investment on the network infrastructure."

Mr. Gurumurthy Iyer
Director, Facilities. I2 Technologies

Upgrade with the innovators in network infrastructure solutions

ADC has been leading the development of infrastructure technology for nearly 75 years and was the first manufacturer to prove the viability of a 10 Gig solution over UTP copper back in 2004. With thousands of patents worldwide, we constantly invest in innovation to stay at the cutting edge of network capability. We also offer the broadest product portfolio in the industry. So you know the infrastructure we provide is unrivalled in power and performance.

At ADC we manufacture and distribute a complete portfolio of standards-based solutions that lead the field. Network Managers across the world specify ADC's Structured Cabling Solutions to keep their networks running at maximum capacity and maximum efficiency every second of every day. By choosing us as your network provider partner, your organisation will benefit from a number of market-leading features that will give you a superior network capability and a distinct competitive advantage.

The flexibility to meet your precise needs

UTP, STP and fibre. Three powerful technologies, each with its own strengths and benefits, yet many providers offer only one. That means the networks they build are constrained by the technology they can provide. At ADC we are truly impartial. We don't have a favoured technology to push, instead we can select from the full range of solutions to create the infrastructure that really fits your needs exactly.

A unique Zero Bit Error warranty

ADC can offer you a Zero Bit Error warranty, bringing you the reassurance that your network will be completely free of bit errors (as a result of the cabling infrastructure) during the full warranty period of 20 years. Whichever network solution you choose – singlemode or multimode fibre, shielded or unshielded copper – you're automatically guaranteed full data bandwidth from any port to any port 24x7, 365 days a year and are covered with a 20 year warranty underwritten by ADC when installed by a TrueNet® Integrator (ADC Approved Integrator).

Every single product is compliant

At ADC, we ensure every single component in your channel adheres to the standards at a channel, permanent link and component level so you are assured of a superior, reliable network.

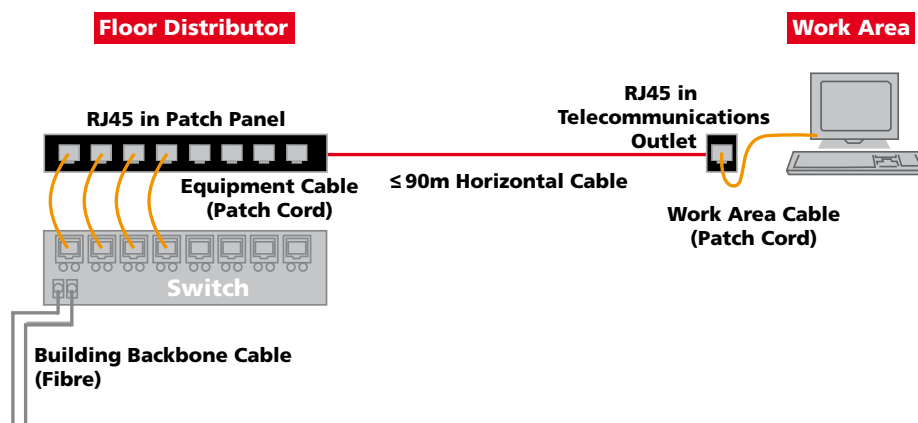

A global presence

We operate in over 100 countries across the globe. With offices and representatives throughout the Americas, EMEA (Europe, Middle East & Africa) Asia Pacific and India, we understand the specific requirements of local markets, and we have the specialised equipment to meet local needs. Our professionals and partners are on the ground ensuring that our clients' infrastructures work and continue to work 24/7. Wherever you are, we're there too.

A focus on partnership

As an organisation we value long-term customer relationships. ADC can work closely with you to design your network, helping to optimise performance while also considering specific issues such as environmental responsibility and ease of installation.

Industry leaders

Our products and solutions don't simply meet or exceed all the major industry standards, we are actively involved in establishing those standards too. Due to our leading role in industry organisations such as the International Organisation for Standardisation (ISO) and the Telecommunications Industry Association (TIA) you can be sure we have the expertise to deliver the next-generation products first.

Independently tested and verified

Independent testing means little if the manufacturer knows what products will be tested and when. That's why ADC was the first to participate in the Premium Verification Programme, providing truly independent testing on all components. Third-party assessors can take any product from our manufacturing line or any distribution outlet to test it without giving any notification. That means the certification that all our products come with can be truly trusted.

This is why you should choose ADC

- We provide a complete range of UTP, STP and fibre connectivity, so instead of forcing a solution upon you, we can create the network that's exactly right for you.
- Our products aren't just innovative, they meet and surpass standards too.
- We strive for technical excellence, offering truly component compliant solutions for 10 Gigabit Ethernet.
- We have a global presence, so can tailor solutions to local environments.
- We give unbeatable warranties to ensure your network keeps on running at maximum efficiency.
- We take a leading role in the industry, so you can rely on our solutions.
- ADC's Augmented Cat 6 Solutions provides 10 Gigabit Ethernet over unshielded (UTP) and shielded (STP) copper to a full 100m at all times and is ideal for high video bandwidths, digital video and voice (VoIP).
- ADC has been accepted into Cisco's technology developer programme as a 'Solution Enabler.'



ADC's Augmented Cat 6 Solutions

– Unshielded Twisted Pair (UTP)

The world's favourite network technology

Unshielded twisted-pair (UTP) provides a straightforward and cost-effective way of moving to 10GBASE-T (10 Gigabit Ethernet), giving your organisation ten times the performance of Category 6, but at only little extra cost.

As with any of our solutions you can be sure we meet and exceed the very latest standards. With ADC's Augmented Cat 6 Solutions UTP, in addition to the channels and permanent links, we also guarantee component compliance, so you know every single part of your network is working 100% giving you complete peace of mind.

UTP solutions from ADC meet and exceed the channel, permanent link and component compliance requirements for Class E_A based on Category 6A components to support 10GBASE-T:

- ISO / IEC 11801:2002 Amendment 1 (international standard) defines Class E_A channel compliance.
- ISO / IEC 11801:2002 Amendment 2 (international standard) defines Class E_A permanent link and Category 6A component compliance.
- TIA-568-B.2-10. Defines Category 6A channel, permanent link and component compliance.

ADC's Cat6_A UTP cabling can run 10 Gig over any distance up to 100m. As we offer the full range of solutions, we can help you ascertain whether UTP or STP is best for your business, then design the network and provide the products to ensure a network every single end user can rely on.

A full product portfolio

Cat6_A horizontal cable

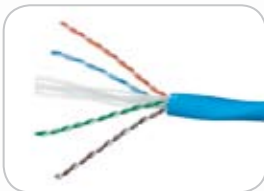

With an innovative 'barley twist' design to maintain separation between cables and give superior performance against alien cross talk.

24 port patch panel



An industry first design, with 'PLM ready' (Physical Layer Management) technology to enable a seamless and non-disruptive future upgrade to intelligent management of the network without the need to disturb the permanent cabling.

Cat6_A punchdown jack



Innovative design for quicker installation maintaining superior cable management.

Patch cords



We offer a full range of solutions:

1. PVC sheathing to give you superior flexibility.
2. Low smoke zero halogen (LSZH) to meet local fire regulations where needed.

Factors to consider with UTP

A number of factors can determine what type of network would be best for your organisation. Because we offer the full complement of solutions, we can assess your situation to recommend the ideal network, taking a number of factors into account:

- Speed of installation required.
- The physical space available.
- Commercial considerations including cost to deploy and cost of ownership.
- Your current environment, including what technology your colleagues are used to.



ADC's Augmented Cat 6 Solutions

– Shielded Twisted Pair (STP)

An increasingly popular solution for a robust network

Shielded solutions have traditionally made up only a fraction of the world's enterprise networks. Yet this is set to change as more and more organisations are choosing to go shielded.

From the very beginning of copper networking, ADC has provided both STP and UTP solutions to our customers. When it comes to recommending and specifying technology, we will concentrate on what your network needs, rather than what we want to sell.

The best performing STP solutions on the market

- Our shielded cable meets the very highest performance standards and is proven to give the very best protection against cross-talk.
- Our Cat6_A Solutions patch cords provide cable management at each end of the cable, making performance second to none.
- A recent independent test by LANline Magazine found the ADC jack was the very best available, providing the greatest "headroom".

STP solutions from ADC meet and exceed the channel and permanent link requirements for Class E_A based on Category 6A components to support 10GBASE-T:

- ISO / IEC 11801:2002 Amendment 1 (international standard) defines Class E_A channel compliance.
- ISO / IEC 11801:2002 Amendment 2 (international standard) defines Class E_A permanent link and Category 6A component compliance.
- TIA-568-B.2-10. Defines Category 6A channel, permanent link and components compliance.
- ADC's Cat6_A Solutions STP cabling can run 10 Gig over any distance up to 100m. As we offer the full range of solutions, we can help you ascertain whether UTP or STP is best for your business, then design the network and provide the products to ensure a network every single end user can rely on.

The full range of market-leading products

With a truly global presence, ADC can provide country-specific products for any STP network. So whatever your needs, wherever your offices and data centres are based, we provide the full range of solutions to help you.

We offer a complete portfolio of STP cable, jacks, patch panels and patch cords to build whatever network you require:

Horizontal cables



The twisted pairs are covered with a braided screen (S/FTP) which guarantees outstanding shielded properties.

Patch panels



Shielded patch panels are compliant with the Category 6_A standard at a component level.

Jacks



Innovative design for quicker installation maintaining superior cable management.

Patch cords



Our STP patch cord has different cable managers at each end, which means no crossovers; optimising transmission across your system to create a network you can rely on 100%.

The best performing STP jack on the market

As the table shows, independent tests have confirmed that the STP jack is the very best product available. When you specify ADC, you know your network is as robust and efficient as possible.

Factors to consider with STP

Ask us to design your network and we will work closely with you to understand your needs, taking a number of factors into account to assess whether STP could be right for you:

- A shielded solution offers significant “headroom” (performance above that specified by the standards), with solid protection against alien cross talk, so cables can run alongside each other without compromising data.
- Alien cross talk is eliminated by the design of the components. This removes the need to test after implementation, so you keep your costs down.

STP cables offer a robust solution, as the individual pair shielding provides excellent protection during installation. The range of TrueNet® Integrators we work with means you can be sure the network will be installed expertly and effectively – and you get the TrueNet® Warranty.

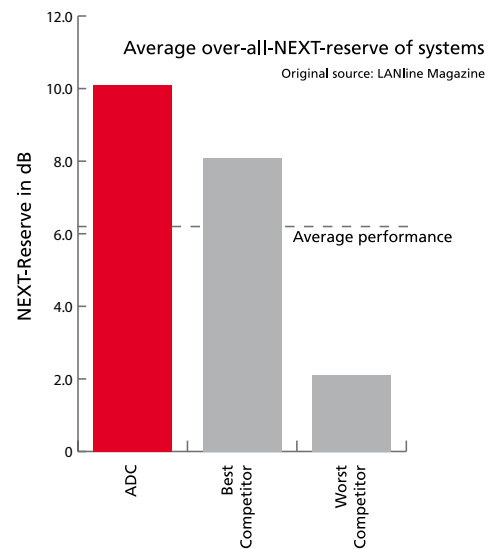

Protection against electromagnetic interference

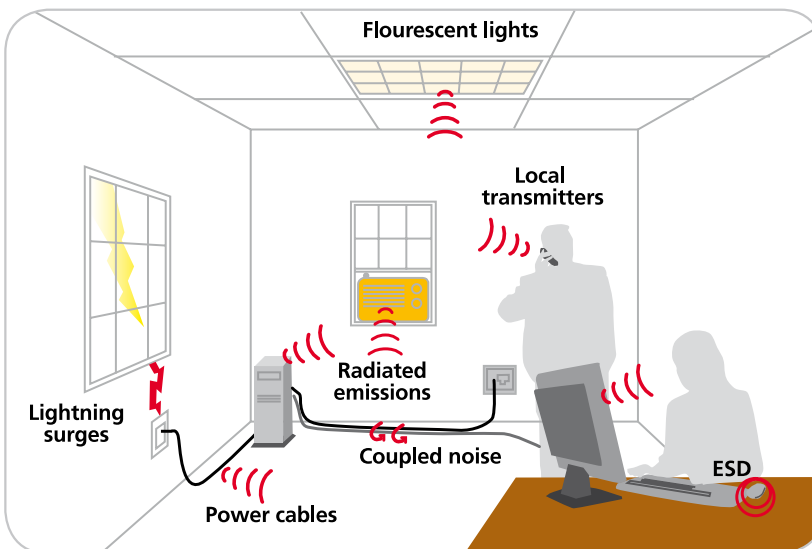

A shielded solution protects against Electro Magnetic Interference (EMI), so equipment such as electrical lighting or lift shaft cabling will not affect data travelling along the cable.

Fibre

The very *highest performance* for your network

Although we built our reputation on copper connectivity, at ADC we also lead the way in fibre optic technologies. Thanks to an innovative range of cutting-edge products, as well as our expertise in fibre solutions, we can plan and implement the ideal network for your organisation.

As the only provider who can offer you the full range of 10 Gig solutions, we are uniquely placed to be able to create a fully integrated network using the very best of every available technology. We are your single point of contact for a complete end-to-end solution.

Tailored to your organisation's needs

In a copper solution, the network must adhere to a clearly defined set of components, which makes certification crucial. Yet with fibre, networks can be more flexible, allowing a range of options for components and routes to make up the channel.

At ADC, we know that every single Data Centre is unique. Thanks to our fully comprehensive portfolio of leading-edge fibre technologies, we can help you develop your network to meet your current and future needs precisely.

From Data Centre patching solutions to world-class singlemode and multimode connectivity, we have the complete range of products and the expertise to help create the ideal solution for you. Whether you are deploying fibre solely in the backbone or right to the desk, our optical products ensure your network runs at peak performance, 24 hours a day, 365 days a year.

Optimise, don't compromise

In the migration from 1 Gig to 10 Gig, the performance of your fibre optic cable becomes critical. Simply knowing a signal is being transmitted from one end of the cable to the other is no longer good enough. You have to be absolutely certain the signal is as pure and powerful as possible. Any differential mode delay (DMD) within the fibre solution will compromise the signal and seriously impede the entire network.

That's why it's vital to specify the very best when installing fibre. By choosing ADC, you are assured that the fibre interconnecting the infrastructure is as robust as every other element in the network.

We offer the full range of fibre solutions and products to create the ideal network for your organisation. We will consult with you to ascertain which solution is right for you:

Singlemode solutions (OS1)

- Ideal where you need to achieve a greater distance.
- Singlemode is also ideal if you envisage more data throughput in the future, as our singlemode solution can introduce CWDM technology, where 8 wavelengths travel down one fibre.

Multimode (OM3 and OM3e grade)

- Laser-optimised fibre.
- Vertical Cavity Surface Emitting Laser (VCSEL) technology enables 10 Gig along multimode fibre networks.

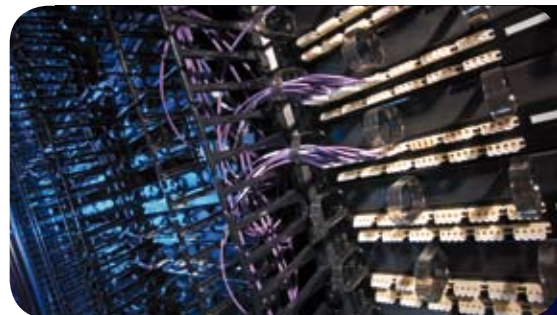

The responsible choice for the data centre

Data Centres consume a vast amount of energy. By reducing the power at every link you can substantially cut the energy used across the data centre, delivering cost savings in turn.

Fibre optic interfaces consume less power than their copper equivalent at 10 Gig. Deploying fibre therefore means you can make your organisation ready for any pressure on the industry to reduce its impact on the environment.

Meeting all fibre standards

ADC fibre solutions comply with all the relevant industry standards:

- ISO / IEC 11801:2002 – Information Technology – Generic cabling for customer premises
- BS EN 50173:2007 series – Information Technology
 - Generic cabling systems
 - Part 2: Office premises
 - Part 5: Data centres
- TIA-568-B series – Commercial building telecommunications cabling
- TIA-942 – Telecommunications infrastructure standard for data centres
- IEEE 802.3ae – 10 Gigabit Ethernet applications for optical fibre cabling



Installation and beyond

Complying with and surpassing all the very latest industry standards, every single one of our products is installation friendly. That means disruption to your site and working environment is kept to a minimum. Our network of TrueNet® Integrators undergo extensive and rigorous training to ensure that every system is expertly installed to the highest specification.

Helping you create a greener network

Over the past 20 years, mankind has consumed more energy at a faster rate than ever before. This trend is particularly apparent in data centres, where power consumption has doubled in the past five years and is expected to rise by 76% from 2005 to 2010. Servers don't just need more power, as they generate heat they also need cooling, which increases energy usage in the data centre still further.

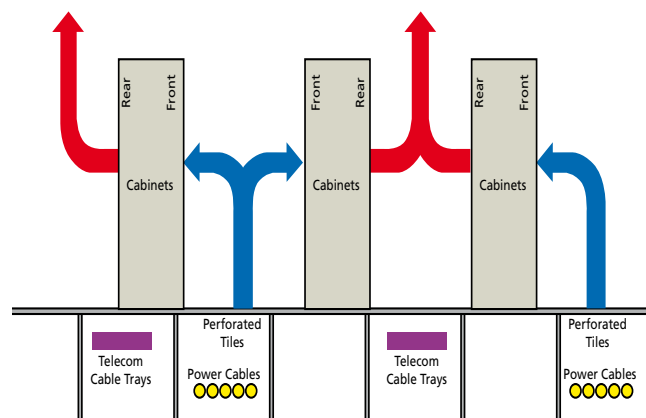

Airflow management in the Data Centre

As environmental concerns become more and more important in the workplace, there will be an increased focus on cutting energy usage across the network. At ADC, we have a long history in meeting environmental requirements and a strong desire to help our customers minimise their environmental issues.

We are committed to preventing pollution and keeping waste to a minimum across all our activities:

- Our product teams work closely with external suppliers to ensure all the materials used in our products comply with environmental legislation
- Since January 1st 2006 all the products we produce have been RoHS (Restriction of Hazardous Substances) compliant.

RoHS is likely to be the first of many environmental directives. As more and more legislation and standards come into place, we can help you make sure your network and your organisation fully meets every standard.

A close-up photograph of a person's hands in a white shirt, holding a black pen over a document. The document contains technical drawings, including a circular diagram with handwritten text 'New' and 'Old' inside it. The background is slightly blurred, showing more of the document and the person's arm.

Expert advice from the industry leaders

There are a number of ways to promote conservation in the data centre. We can act on a consultative basis to help you identify the correct solution for you:

- Server virtualisation: multiple applications run on individual servers, which means fewer servers to power and cool
- Airflow management in cabinets: careful management of cables and servers within a cabinet ensures that air flow remains unimpeded
- Hot aisle / cold aisle configurations: keeping the two aisles separate manages airflow and temperature more efficiently

These are just a few of the top level ways of reducing power usage. Over the years we have developed a number of more detailed activities which we can discuss with you further. ADC has helped a number of clients create a more energy-efficient data centre to keep energy usage and costs down. From the initial design of a data centre through to advice on day-to-day energy usage, we have the expertise to help you stay environmentally compliant.

Decades of *expertise*

– the ADC heritage

Founded in 1935, ADC is one of the world's leading suppliers of global network infrastructure products and services. In 2004, ADC acquired the KRONE Group, a market leader in copper and fibre-based connectivity and cabling.

The integration of the two companies means no other provider is better placed to provide you with the full range of networking solutions, wherever your offices and end users are based. With over 9,000 professionals in over 100 countries across the globe, we are focused on providing all our clients with market-leading products and service to maintain our position as industry leader.

Our customers include world leaders in communications, finance, technology, travel and education sectors. We have already helped over 150 clients migrate to the extraordinary capability and power of 10 Gig, and have the expertise and experience to help your organisation take a similar step.

Recognised and certified by Cisco

ADC has been accepted into Cisco's technology developer programme as a 'Solution Enabler.' This means Cisco recognises our 10 Gig UTP Copper products as being market-leading equipment that will enable Cisco's solutions for its clients. So when you specify ADC, you know our products have met the Cisco standards for quality and compatibility and will complement any Cisco equipment.



Upgrade to the most powerful network yet

Your organisation and what you need from your data and network are all completely unique. That's why we take a consultative approach to support your migration to 10 Gigabit Ethernet, helping you make the right decisions for your business.

To take the next step to extend the performance and maximise the future proofing of your network and your business, contact ADC for a discussion with a local representative. Please refer to the back page of this brochure for contact details.

Engineering for *Uptime*

Designing the System.

Your data centre and network is the epicenter of the organization.

The typical data centre is a high-performance machine constructed of thousands of components. And like the spot welds in the frame of a car, the data center is held together and cannot function reliably without the "spot welds" of structured cabling and connectivity equipment.

ADC's Premier Infrastructure Solutions

- Copper solutions
- Fibre solutions
- Connectivity solutions
- Cable management solutions
- All optimised to maximise system uptime

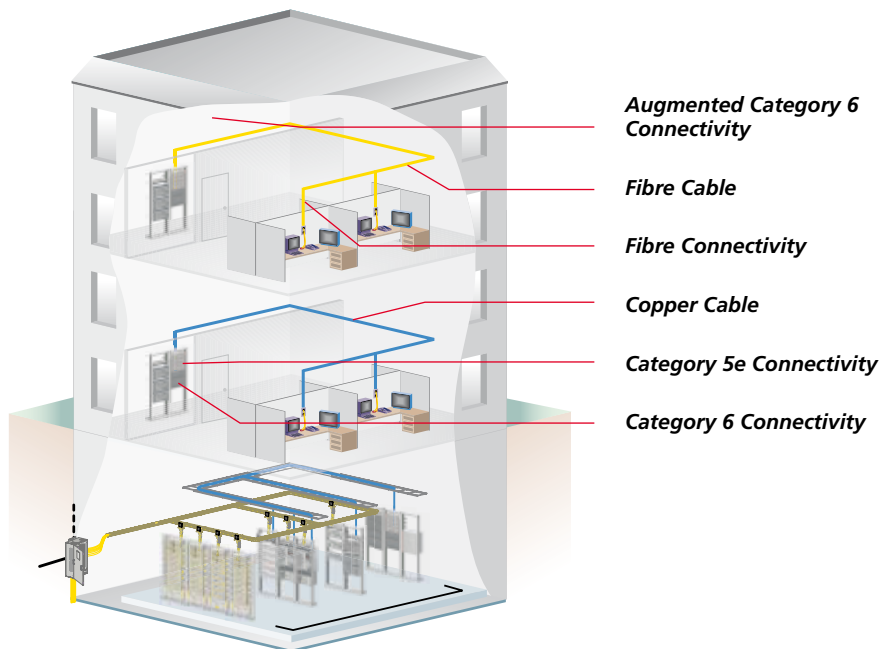

Connectivity solutions are at the foundation of data centre managers' ability to maximize their networking investments and provide a stable, efficient network architecture.

Linda Borovick
Program Director for IDC's Datacenter Networks Program

ADC Structured Cabling Solutions 10 Gigabit Ethernet



www.adc.com/in

Corporate Office & Factory: P B No. 5812, 10 'C' II Phase, Peenya, BANGALORE - 560 058. India
Ph: +91 80 2839 6101 / 6291, Fax +91 80 2372 2753 Toll Free: 1800 425 8232

For a listing of ADC India's sales office locations, please refer to our website

ADC Telecommunications, Inc., P.O. Box 1101, Minneapolis, Minnesota USA 55440-1101

Specifications published here are current as of the date of publication of this document. Because we are continuously improving our products, ADC reserves the right to change specifications without prior notice. At any time, you may verify product specifications by contacting our headquarters office in Minneapolis. ADC Telecommunications, Inc. views its patent portfolio as an important corporate asset and vigorously enforces its patents. Products or features contained herein may be covered by one or more U.S. or foreign patents. An Equal Opportunity Employer

400600IN 06/10 Revision 2 © 2010 ADC Telecommunications, Inc. All Rights Reserved