

# Glide Cable Management Solutions

Vertical and Horizontal Cable Management

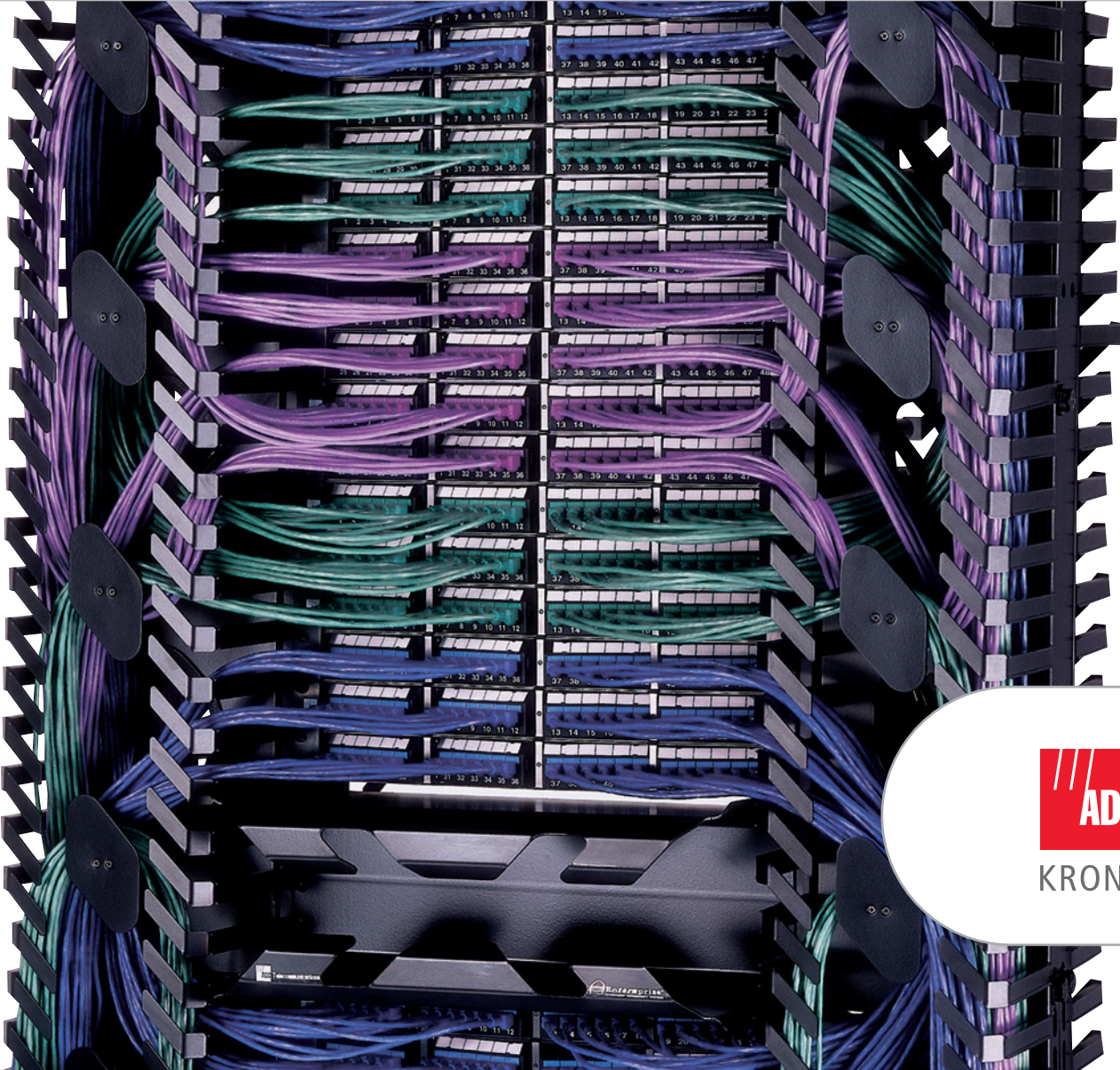

ADC KRONE's patented Glide Cable Management System is the world's first integrated horizontal and vertical cable manager

## Vertical mount managers

### Ordering Information

Description	Catalogue Number
<p><b>Glide 6" vertical cable manager, front only</b> Vertical mounted Glide cable manager, black in colour and 6" (152mm) wide. Eliminates horizontal patch cord minders. The four integrated slack managers allow patch cords of any length to be routed neatly whilst still easily accessible. Ideal for use at the start or end of an installation of racks. To equip both sides of a 19" rack, order two of these parts.</p>	ADCCMVBS06F-2
<p><b>Glide 8" vertical cable manager, front and rear</b> Vertical mounted Glide cable manager, black in colour and 8" (203mm) wide. Patented rib cage design eliminates horizontal patch cord minders and rear cable management trays. The four integrated slack managers allow patch cords of any length to be routed neatly whilst still easily accessible. Ideal for use in between racks as an interconnect. To equip both sides of a 19" rack, order two of these parts.</p>	ADCCMS-08
<p><b>Glide 10" vertical cable manager, front and rear</b> Vertical mounted Glide cable manager, black in colour and 10" (254mm) wide. Patented rib cage design eliminates horizontal patch cord minders and rear cable management trays. The four integrated slack managers allow patch cords of any length to be routed neatly whilst still easily accessible. Ideal for use in between racks as an interconnect. To equip both sides of a 19" rack, order two of these parts.</p>	ADCCMS-10



Glide 6"

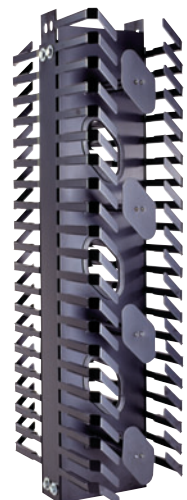

Glide 8"

## Hinged covers

### Ordering Information

Description	Catalogue Number
<p><b>Glide 6" hinged cover</b> Hinged black cover to suit the Glide 6" vertical cable manager, front only. The kit contains (2) covers for one side of the 19" rack. To cover both sides of a 19" rack, order two kits.</p>	ADCC06-2
<p><b>Glide 8" hinged cover</b> Hinged black cover to suit the Glide 8" vertical cable manager. The kit contains (4) covers for both the front and rear. To equip both sides of a 19" rack both front and rear, order two kits.</p>	ADCCMVIBC08B4
<p><b>Glide 10" hinged cover</b> Hinged black cover to suit the Glide 10" vertical cable manager. The kit contains (4) covers for both the front and rear. To equip both sides of a 19" rack both front and rear, order two kits.</p>	ADCCMVIBC10B4



Hinged cover

For too long, cable management has been a time consuming job for IT Managers. As organisations grow in size they quickly outgrow their cabling infrastructure and 19" cabinets and racks become overcrowded. Even with ample horizontal patch cord minders installed, patch cords still seem to get tangled. Simple adds, moves and changes can become time consuming and frustrating. It is inevitable that in a patch panel system, there will sometimes be excess lengths of cord. This either takes up the space in the patch cord minder or clutters the front of the rack.

The Glide vertical managers attach to each side of the 19" rack, ensuring that the front of rack is left available for patch panels and other patching equipment. As horizontal patch cord minders are no longer required for every patch panel, more rack units can be populated with patch panels or any other patching equipment. This in turn leads to a saving in floor space, which is valuable in high-density environments such as call centres. The Glide system works by managing excess lengths of cable through a series of vertical spools called 'slack managers' located within the Glide verticals. Each Glide vertical also has a rib cage, which is its own set of outer cable managers. The patented rib cages are designed to accommodate patch cords at the front of the rack and terminated solid cables at the rear of the rack. While decreasing the initial installation time, this provides greater access for technicians when maintenance is required.

ADC KRONE's Glide Cable Management System is the solution to long term efficiency in the building distributor, floor distributor or any IT environment where patching is required. No matter how long the patch cords and no matter how many cords are used, Glide provides a neat, well managed and user friendly cabling infrastructure allowing moves, adds and changes to take place quickly and accurately.



#### Features

- Integrated front, rear, horizontal and vertical cable management
- Patented rib cage design eliminates horizontal patch cord minders and rear cable management trays
- Greater patch panel density over traditional 19" cabinets
- Built-in bend radius protection ensures network integrity
- Designed for quick and easy moves, adds and changes
- Built-in slack managers allows excess patch cord length to be easily managed avoiding cable management nightmares
- Can be used as a single rack or as inter-rack unit
- Optional crossover troughs and horizontal cable managers available



## Horizontal mount managers

Ordering Information	
Description	Catalogue Number
<p><b>Glide 2RU horizontal crossover trough</b> Horizontal Glide crossover trough handles all cable and patch cord routing requirements, black in colour and 2RU. Designed for top, middle or bottom of rack. Built in bend radius protection ensures network integrity. To equip both the front and rear of the 19" rack, order two of these parts.</p>	ADCCMTG02
<p><b>Glide 4RU horizontal crossover trough</b> Horizontal Glide crossover trough handles all cable and patch cord routing requirements, black in colour and 4RU. Designed for top, middle or bottom of rack. Built in bend radius protection ensures network integrity. To equip both the front and rear of the 19" rack, order two of these parts.</p>	ADCCMTG04
<p><b>Glide 2RU horizontal cable manager</b> Horizontal Glide cable manager handles all cable and patch cord routing requirements, black in colour and 2RU. Designed for top, middle or bottom of rack. Built in bend radius protection ensures network integrity. Front cover hinges down to allow easy access when required. To equip both the front and rear of the 19" rack, order two of these parts.</p>	ADCCMHIB-2U



## Rack

Ordering Information	
Description	Catalogue Number
<p><b>Glide 19" rack, 44RU</b> 19" rack, black in colour, accommodates cage nuts.</p>	6460 1 141-00



Rack 44 RU

GLIDE CABLE MANAGEMENT SOLUTIONS



# Glide Cable Manager

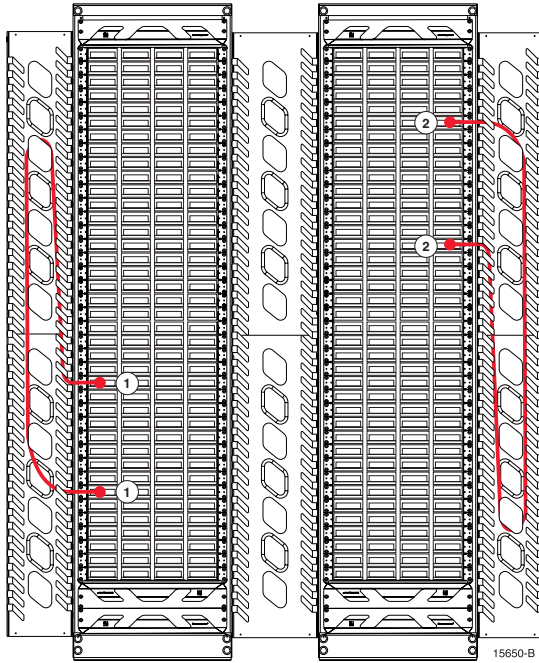

Figure 1

Upper and lower crossover managers with vertical cable managers enable easy, intuitive cable routing.

Figure 1: Connect ports to the same side of the same bay using vertical cable managers with slack managers for handling extra cable lengths.

Figure 2: Vertical cable managers integrate cables and maintain neatness in ladder rack and raised floor applications.

Figure 3: Upper and lower crossover managers enable connection of ports on opposite sides of the bay while maintaining an orderly appearance.

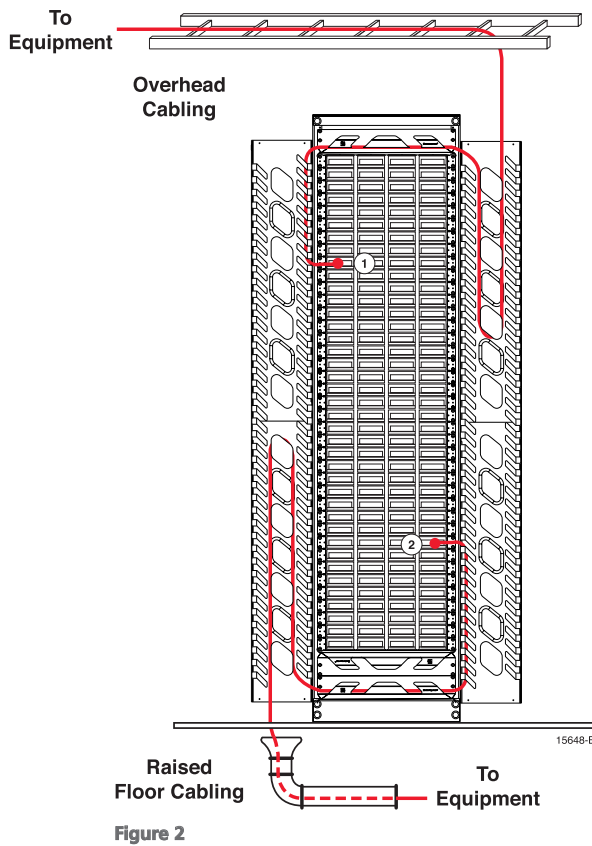

Figure 2

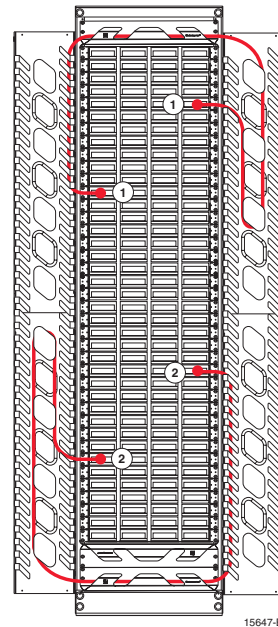
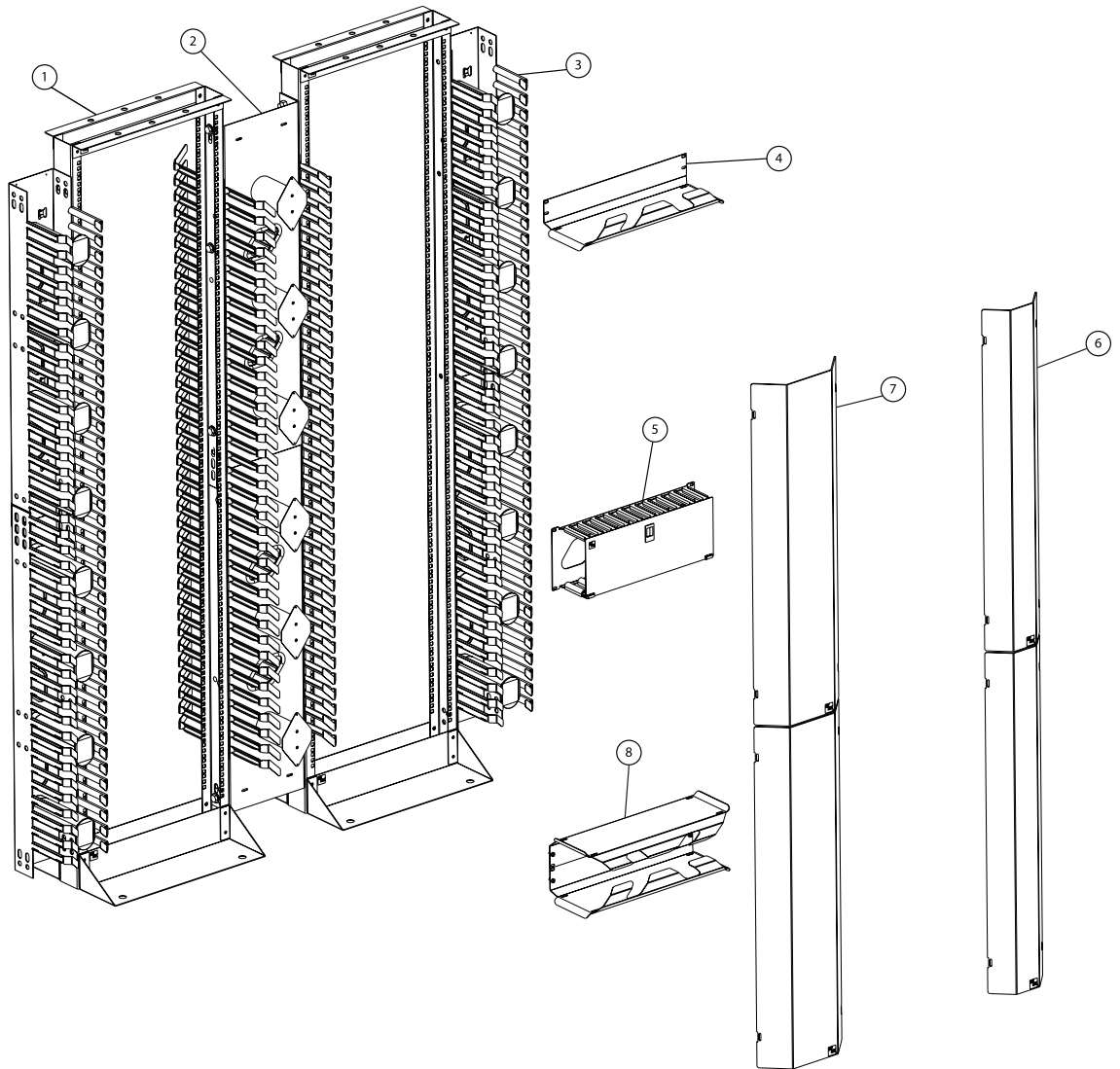

Figure 3

# Glide Cable Management Solutions

GLIDE CABLE MANAGEMENT SOLUTIONS



## Key (Catalogue numbers)

- |                    |                   |
|--------------------|-------------------|
| 1 - 6460 1 141-00  | 5 - ADCCMHIB-2U   |
| 2 - ADCCMS-08      | 6 - ADCC06-2      |
| 3 - ADCCMVIBS06F-2 | 7 - ADCCMVIBC08B4 |
| 4 - ADCCMTG02      | 8 - ADCCMTG04     |



### [www.adckrone.com/au](http://www.adckrone.com/au)

AUSTRALIA 2 Hereford Street, Berkeley Vale NSW 2261  
Mailing Address: PO Box 335, Wyong NSW 2259, Australia  
TECH SUPPORT 1800 801 298 helpdesk.au@adckrone.com

### [www.adckrone.com/nz](http://www.adckrone.com/nz)

NEW ZEALAND 2 Nevis Street, Petone, Wellington  
Mailing Address: PO Box 38-177, Wellington Mail Centre 6008, New Zealand

ADC Telecommunications, Inc., P.O. Box 1101, Minneapolis, Minnesota USA 55440-1101

Specifications published here are current as of the date of publication of this document. Because we are continuously improving our products, ADC reserves the right to change specifications without prior notice. At any time, you may verify product specifications by contacting your local ADC KRONE office. ADC Telecommunications, Inc. views its patent portfolio as an important corporate asset and vigorously enforces its patents. Products or features contained herein may be covered by one or more U.S. or foreign patents. An Equal Opportunity Employer.

6311 8/05 © 2005 ADC Telecommunications, Inc. All Rights Reserved.