

Technical Reference

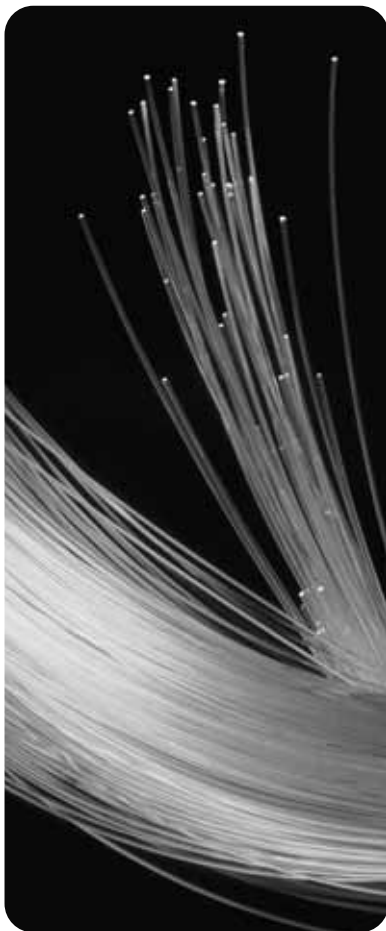

- Introduction2.2
- The Four Elements of Fibre Cable Management2.3
- Fibre Distribution Systems and the ODF2.6
- Housing of Optical Equipment2.11
- Interconnect and Cross-Connect Applications.....2.13
- On-Frame and Off-Frame Splicing.....2.17
- Racks, Cable Raceways and Density2.20
- Future Growth2.21
- Effect of High Density.....2.21
- Specifying Fibre Cable Management Systems:
- Cost and Value2.21
- Relative Cost and True Value of Fibre
- Cable Management2.21
- Conclusion2.22

Lower operational costs, greater reliability and flexibility in service offerings, quicker deployment of new and upgraded services—these are the characteristics of a successful service provider in a competitive global market. Service providers continue to build out high-bandwidth networks around the world. These networks use a great deal of fibre—the medium that meets both their bandwidth and cost requirements. But just deploying the fibre is not enough; a successful fibre network also requires a well built infrastructure based on a strong fibre cable management system. Management of the fibre cables has a direct impact on network reliability, performance, and cost. It also affects network maintenance and operations, as well as the ability to reconfigure and expand the network, restore service, and implement new services quickly. A strong fibre cable management system provides bend radius protection, cable routing paths, cable accessibility and physical protection of the fibre network. If these concepts are executed correctly, the network can deliver its full competitive advantages.

Facing ever-increasing competition, service providers deploy fibre because of its high bandwidth and its ability to deliver new revenue-generating services profitably.

A look at the numbers clearly tells the bandwidth story. While twisted pair copper cable is limited in its bandwidth capacity to around 6Mbps, and coaxial cable is limited to an STM-1 level of 155Mbps, singlemode fibres are commonly used at STM-1 (155Mbps), STM-4 (622Mbps), STM-16 (2.5GBPS), and even higher levels around the world (see Table 1).

Signal	Bit Rate (Mbps)	Voice Channel	Medium
DS0	0,064	1	TWISTED PAIR
DS1	1,540	24	
E1	2,040	30	
DS2	6,310	96	
E2	8,190	120	COAXIAL CABLE
E3	34,000	480	
DS3	44,730	672	
STS3 (STM-1)	155,520	2016	
STS-1OC-1	51,840	627	FIBRE OPTIC CABLE
(STM-1) STS-3/OC-3	155,520	2016	
(STM-4) STS-12/OC-12	622,080	8064	
(STM-16) STS-48/OC-48	2488,320	32.256	
STS-192/OC-192	9953,280	129.024	

Table 1. Transmission hierarchies

The use of fibre translates into more revenue for providers, especially from business customers who demand high-bandwidth networks delivering voice, video and data at increased speed, assured service levels and guaranteed security. A single dedicated E1 circuit to a corporation can easily generate around US \$19,000 revenue per year. A single fibre operating at an STM-4 level carrying 480 E1 circuits can generate as much as US \$6,400,000 per year. Potential revenue varies by country, system usage, fibre allocation and other factors, but the bottom line is clear: a single fibre cable can carry a larger amount of revenue-producing traffic than a single twisted pair or coaxial cable can.

Service providers are pushing fibre closer and closer to the end user, whether that is fibre to the home or to the desk. An increasing amount of an operator's revenue flows through the fibre. To realise fibre's enormous advantage in revenue-producing bandwidth, fibre cables must be properly managed. Proper management affects how quickly new services can be turned up and how easily the network can be reconfigured. In fact, fibre cable management, the manner in which the fibre cables are connected, terminated, routed, spliced, stored and handled, has a direct and substantial impact on the networks' performance and profitability.

Technical Reference

The Four Elements of Fibre Cable Management

There are four critical elements of fibre cable management: bend radius protection; cable routing paths; cable access; physical protection. All four aspects directly affect the network's reliability, functionality, and operational cost.

Bend Radius Protection

There are two basic types of bends in fibre—microbends and macrobends. As the names indicate, microbends are very small bends or deformities in the fibre, while macrobends are larger bends (see Figure 1).

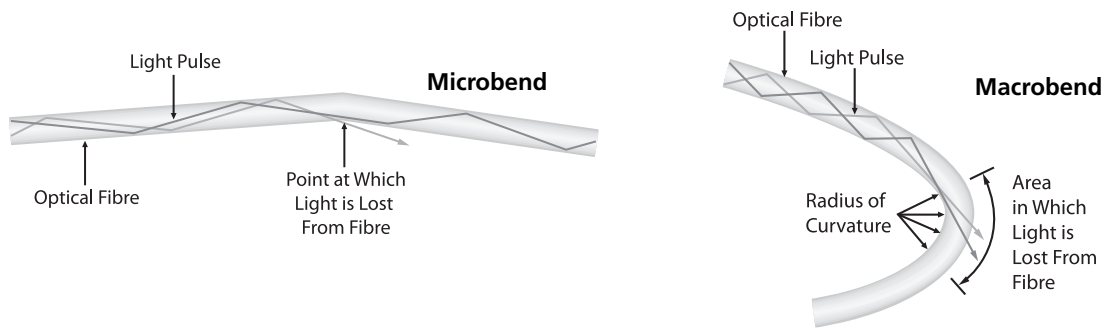

Figure 1. Microbends and macrobends

The fibre's radius around bends impacts the fibre network's long-term reliability and performance. Simply put, fibres bent beyond the specified minimum bend diameters can break, causing service failures and increasing network operations costs. Cable manufacturers, Internet and telecommunications service providers, and others specify a minimum bend radius for fibres and fibre cables. The minimum bend radius will vary depending on the specific fibre cable. However, in general, the minimum bend radius should not be less than ten times the Outer Diameter (OD) of the fibre cable. Thus a 3mm cable should not have any bends less than 30mm in radius. Telcordia recommends a minimum 38mm bend radius for 3mm patch cords (Generic Requirements and Design Considerations for Fiber Distributing Frames, GR-449-CORE, Issue 1, March 1995, Section 3.8.14.4). This radius is for a fibre cable that is not under any load or tension. If a tensile load is applied to the cable, as in the weight of a cable in a long vertical run or a cable that is pulled tightly between two points, the minimum bend radius is increased, due to the added stress.

There are two reasons for maintaining minimum bend radius protection: enhancing the fibre's long-term reliability; and reducing signal attenuation. Bends with less than the specified minimum radius will exhibit a higher probability of long-term failure as the amount of stress put on the fibre grows. As the bend radius becomes even smaller, the stress and probability of failure increases. The other effect of minimum bend radius violations is more immediate; the amount of attenuation through a bend in a fibre increases as the radius of the bend decreases. The attenuation due to bending is greater at 1550nm than it is at 1310nm—and even greater at 1625nm. An attenuation level of up to 0.5dB can be seen in a bend with a radius of 16mm. Both fibre breakage and added attenuation have dramatic effects on long-term network reliability, network operations costs, and the ability to maintain and grow a customer base.

In general, bend radius problems will not be seen during the initial installation of a Fibre Distribution System (FDS), where an outside plant fibre cable meets the cable that runs inside a central office or headend. During initial installation, the number of fibres routed to the Optical Distribution Frame (ODF) is usually small. The small number of fibres, combined with their natural stiffness, ensures that the bend radius is larger than the minimum. If a tensile load is applied to the fibre, the possibility of a bend radius violation increases. The problems grow when more fibres are added to the system. As fibres are added on top of installed fibres, macrobends can be induced on the installed fibres if they are routed over an unprotected bend (see Figure 2). A fibre that had been working fine for years can suddenly have an increased level of attenuation, as well as a potentially shorter service life.

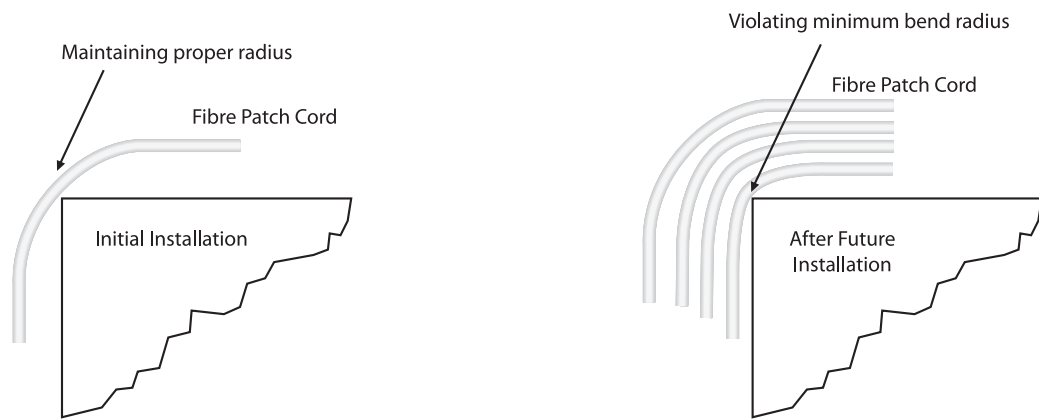

Figure 2. Effect of adding fibres

The fibre used for analogue video CATV systems presents a special case. Here, receiver power level is critical to cost-effective operation and service quality, and bend radius violations can have different but equally dramatic effects. Analogue CATV systems are generally designed to optimise transmitter output power. Due to Carrier-to-Noise-Ratio (CNR) requirements, the receiver signal power level is controlled, normally to within a 2dB range. The goal is for the signal to have enough attenuation through the fibre network, including cable lengths, connectors, splices and splitters, so that no attenuators are needed at the receiver. Having to attenuate the signal a large amount at the receiver means that the power is not being efficiently distributed to the nodes, and possibly more transmitters are being used than are necessary. Since the power level at the receiver is more critical, any additional attenuation caused by bending effects can be detrimental to picture quality, potentially causing customers to be dissatisfied and switch to other vendors.

Since any unprotected bends are a potential point of failure, the fibre cable management system should provide bend radius protection at all points where a fibre cable makes a bend. Having proper bend radius protection throughout the fibre network helps ensure the network's long-term reliability, thus helping maintain and grow the customer base. Reduced network down time due to fibre failures also reduces the operating cost of the network.

Cable Routing Paths

The second aspect of fibre cable management is cable routing paths. This aspect is related to the first as improper routing of fibres by technicians is one of the major causes of bend radius violations. Routing paths should be clearly defined and easy to follow. In fact, these paths should be designed so that the technician has no other option than to route the cables properly. Leaving cable routing to the technician's imagination leads to an inconsistently routed, difficult-to-manage fibre network. Improper cable routing also causes increased congestion in the termination panel and the cableways, increasing the possibility of bend radius violations and long-term failure. Well-defined routing paths, on the other hand, reduce the training time required for technicians and increase the uniformity of the work done. The routing paths also ensure that bend radius requirements are maintained at all points, improving network reliability.

Additionally, having defined routing paths makes accessing individual fibres easier, quicker and safer, reducing the time required for reconfigurations. Uniform routing paths reduce the twisting of fibres and make tracing a fibre for rerouting much easier. Well-defined cable routing paths also greatly reduce the time required to route and reroute patch cords. This has a direct effect on network operating costs and the time required to turn-up or restore service.

Technical Reference

The Four Elements of Fibre Cable Management

Cable Access

The third element of fibre cable management is the accessibility of the installed fibres. Allowing easy access to installed fibres is critical in maintaining proper bend radius protection. This accessibility should ensure that any fibre can be installed or removed without inducing a macrobend on an adjacent fibre. The accessibility of the fibres in the fibre cable management system can mean the difference between a network reconfiguration time of 20 minutes per fibre and one of over 90 minutes per fibre. Accessibility is most critical during network reconfiguration operational and directly impacts operational costs and network reliability.

Physical Fibre Protection

The fourth element of fibre cable management is the physical protection of the installed fibres. All fibres should be protected throughout the network from accidental damage by technicians and equipment. Fibres routed between pieces of equipment without proper protection are susceptible to damage, which can critically affect network reliability. The fibre cable management system should therefore ensure that every fibre is protected from physical damage.

Technical Reference

Fibre Distribution Systems and the ODF

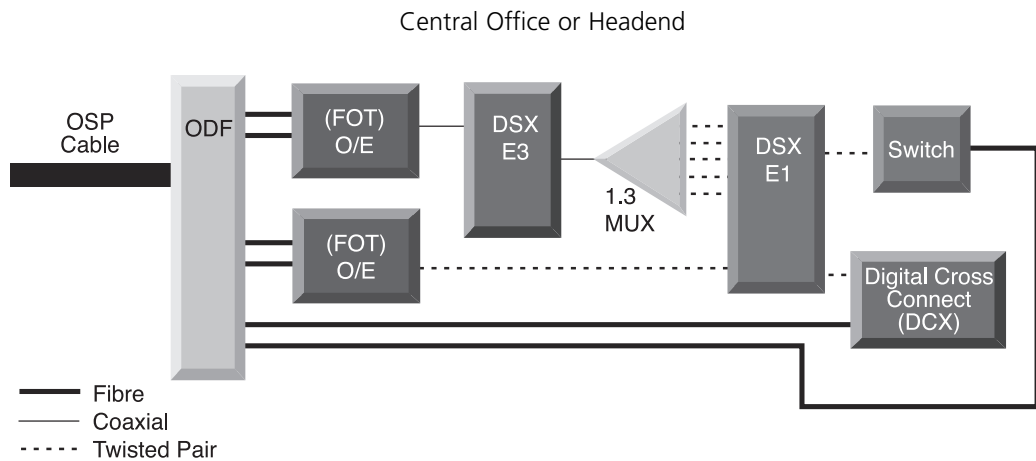

Figure 3. Optical Distribution Frame (ODF) functionality

All four elements of fibre cable management come together in the fibre distribution system, which provides an interface between Outside Plant (OSP) fibre cables and Fibre Optic Terminal (FOT) equipment (see Figure 3). A fibre distribution system handles four basic functions: termination, splicing, slack storage, and housing of passive optical components.

Non-Centralised System

- KEY
- ODF: Optical Distribution Frame
 - FOT: Fibre Optic Terminal Equipment
 - FUT: Future Frame (Growth)

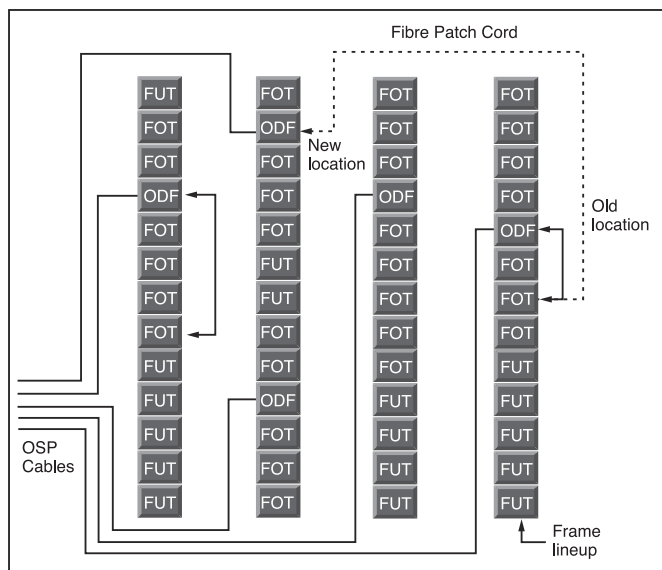

Figure 4. Non-centralised office floor plan for fibre distribution network layout

A fibre distribution system can be non-centralised or centralised. A non-centralised fibre distribution system is one in which the OSP fibre cables come into the office and are routed to an ODF located near the FOT equipment they are serving. Each new OSP fibre cable run into the office is routed directly to the ODF located nearest the equipment with which it was originally intended to work (see Figure 4). This is how many fibre networks started out, when fibre counts were small and future growth was not anticipated. As network requirements change, however, the facilities that use the OSP fibres also change. Changing a particular facility to a different OSP fibre can be very difficult, since the distance may be great and there tends to be overlapping cable routing. While a non-centralised fibre distribution system may initially appear to be a cost-effective and efficient means to deploy fibre within an office, experience has shown that major problems with flexibility and cable management will arise as the network evolves and changes. These reasons suggest the need for a centralised fibre distribution system.

Centralised System

KEY

ODF: Optical Distribution Frame

FOT: Fibre Optic Terminal Equipment

FUT: Future Frame (Growth)

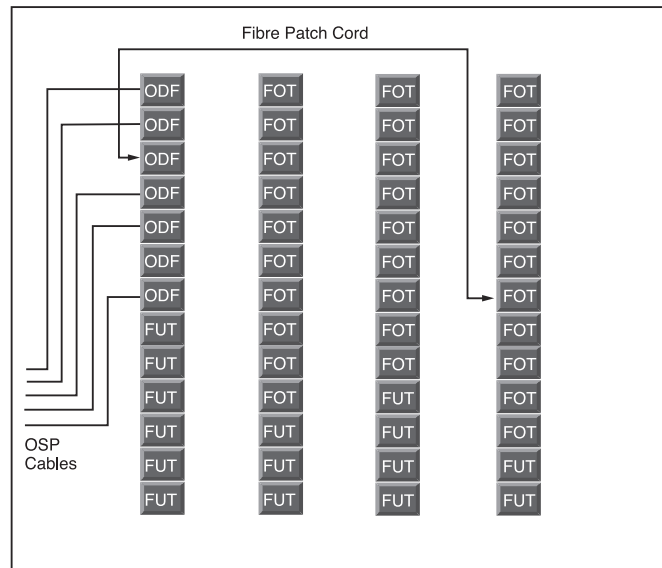

Figure 5. Centralised fibre distribution network layout

A centralised fibre distribution system provides a network that is more flexible, more cost-efficient to operate and that has better long-term reliability. A centralised fibre distribution system brings all OSP fibres to a common location at which all fibre cables to be routed within the office originate, see Figure 5. A centralised fibre distribution system consists of a series of ODF, is also known as Fibre Distribution Frames (FDF). The centralised ODF allows all OSP fibres to be terminated at a common location, making distribution of the fibres within the OSP cable to any point in the office easier and more efficient. Having all OSP fibre in one location and all FOT equipment fibres coming into the same general location reduces the time and expense required to reconfigure the network in the event of equipment changes, cable cuts, or network expansion.

Let's return now to the four basic functional requirements of any fibre distribution system: terminations, splicing, slack storage, and housing of passive optical components.

In order for the signal to get from one fibre to another, the cores of the two fibres need to be joined, i.e. brought into near-perfect alignment. The measurements that determine the quality of the junction are insertion loss and return loss. Insertion Loss (IL) is a measure of the power that is lost through the junction ($IL = -10\log(P_{out}/P_{in})$), where P is power. An IL of 0.3dB is equivalent to about 7 percent of the power being lost. Return Loss (RL) is a measure of how much power is reflected back to the source from the junction ($RL = 10\log(P_{in}/P_{back})$). A return loss value of 57dB is equivalent to 0.0002 percent of the light being reflected back. There are two means of joining fibres in the industry today: connector terminations and splices.

Terminations

Connector termination in fibre optics refers to the physical joining, using a mechanical connector, of two separate fibres, with the goal of having 100-percent signal transfer. Connector terminations used for junctions are meant to be easily reconfigurable, to allow easy connection and reconnection of fibres. There are several fibre connectors available in the industry today; the most commonly used singlemode types are SC, FC and LC. Typical singlemode ultra polish connectors will provide insertion loss values of <0.3dB and return loss values of >52dB, while singlemode angled polish connectors have insertion loss values of <0.2dB and return loss values of >55dB.

Reliable operation of connectors depends on the correct geometry of the convex polished ferrule endface. The following parameters are routinely checked by interferometric inspection: radius of curvature, apex offset, fibre projection/undercut, polishing angle (see Figure 6).

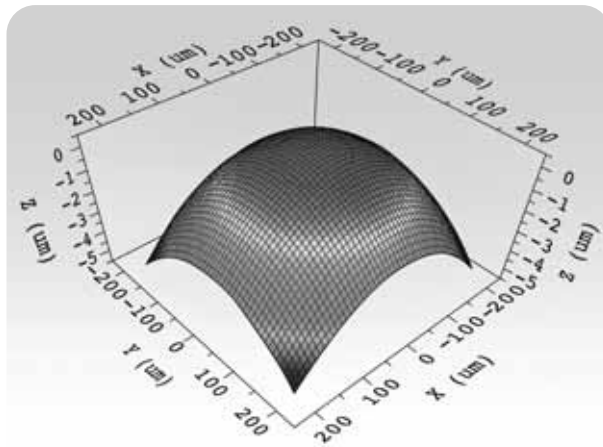

Figure 6.

A connector is installed onto the end of each of the two fibres to be joined. Singlemode connectors are generally factory-installed, to meet requirements for optical performance and long-term reliability. The junction is then made by mating the connectors to each side of an adapter. The adapter holds the connectors in place and brings the fibres into alignment (see Figure 7).

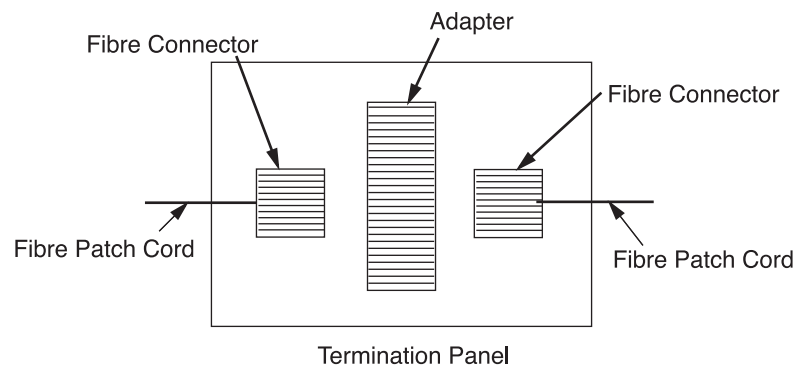

Figure 7. Fibre terminations

The adapters are housed within a termination panel, which provides a location to safely house the adapter/connector terminations and allows easy access to installed connectors. Fibre termination panels typically house from twelve to 144 terminations. Termination panels should adapt easily to any standard style of connector/adapter. This allows easy future growth and also provides more flexibility in evolving network design. Fibre cable management within the termination panel is critical.

Cable management within a termination panel must include correct bend radius protection and physical routing paths. The fibres should have bend radius protection along the route from the adapter port to the panel exit location. The path the fibre follows in getting to the panel exit should also be very clear and well defined. Most cable management problems in termination panels arise from improper routing of patch cords. Improper fibre routing within the panels can make access to installed connectors very difficult, and can cause service-affecting macrobends on adjacent fibres. Connectors should also be removable without the use of special tools, which can be costly and easily lost or left behind. Proper fibre cable management in the termination panel improves network flexibility, performance and reliability while reducing operations costs and system reconfiguration time.

When fibre is used in the local serving loop, such as in hybrid fibre/coax networks or fibre-fed Digital Loop Converters (DLCs), backup fibres run to the Optical Network Unit (ONUs) or to the DLCs. These fibres are provided in case a technician breaks the active fibre or damages the connector during installation and maintenance. In the event of such an occurrence, the signal has to be rerouted from the original active fibre to the backup fibre. This rerouting is done at the OSP termination panel within the ODF. While the fibre appearances on the termination panel are generally located either adjacent to each

other or within a few terminations of each other, this reconfiguration should not jeopardise the integrity of the other installed circuits. If installed fibres must be moved in order to access the target connector, then the probability of inducing a bending loss in those adjacent fibres is increased. That loss could be enough to cause a temporary service outage. These effects are especially pronounced in CATV systems, in which the system attenuation is adjusted to an optimal power level at the receiver to provide the best picture quality. Enabling easy access to individual terminations without disturbing other fibres is an important feature of a termination panel.

Connector Cleaning

Reliable optical networks require clean connectors. Any time one connector is mated to another, both connectors should be properly cleaned and inspected. Dirty connectors are the biggest cause of increased back-reflection and insertion loss in connectors, including angled polish connectors. A dirty ultra polish connector with a normal return loss of >55dB can easily have >45dB reflectance if it is not cleaned properly. Similar comparisons can be made with angled polish connectors. This can greatly affect system performance, especially in CATV applications where CNR is directly related to signal quality.

In order to ensure that both connectors are properly cleaned, the termination panel must allow them both to be easily accessed. This easy access has to be for both the patch cord connector and the equipment or OSP connector on the back side of the termination panel. Accessing these connectors should not cause any significant loss in adjacent fibres.

A system that allows uncomplicated access to these connectors has much lower operating costs and improved reliability. Without easy access to connectors, technicians will take more time to perform their work, delaying implementation of new services or redeployment of existing services. Dirty connectors can also jeopardise the long-term reliability of the network, because dirt and debris can be embedded into the endface of the connector, causing permanent, performance-affecting damage.

Splicing

The other means of joining two fibres is a splice. Splicing in fibre optics is the physical joining of two separate optical fibres with the goal of having 100 percent signal transfer. Splicing connections are meant to be permanent, non-reconfigurable connections. There are two basic splicing methods in use today: mechanical and fusion (see Figure 8).

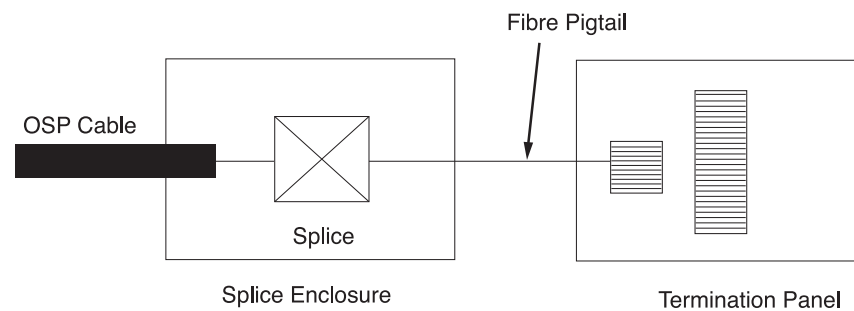

Figure 8. Fibre splicing

Mechanical splicing involves the use of an alignment fixture to bring together and hold two fibres in alignment. Mechanical splices typically give IL values of <0.15dB with return loss values of >35dB and involve the use of an index-matching gel. Fusion splicing uses an electric arc to “weld” two fibres together. Fusion splices typically have insertion loss values of <0.05dB and return loss values of >70dB. Whichever splicing type is used, the ODF needs to provide a location to store and protect the splices.

The splicing function can be performed on the ODF (on-frame splicing) or in a location near the place at which the OSP cables enter the building, such as the cable vault (off-frame splicing). We will discuss on-frame versus off-frame splicing later in this paper. In either situation, the splice enclosure or panel provides a location to store all splices safely and efficiently. The individual splices are housed within a splice tray, generally holding between 12 and 24 splices. The splice trays in turn are housed within a

panel that accommodates between 96 and 192 splices. Large splice enclosures can generally house up to 864 splices in a single unit. For splice enclosures/panels, the most critical fibre cable management features are bend radius and physical protection.

The fibre cable management within the splice enclosure/panel and the splice tray contributes to the long-term reliability of the fibre network and determines the ability to reconfigure or rework any splices. In routing fibres between the enclosure/panel entrance point and the splice tray, enough slack should be provided and made easily accessible for the technicians to perform any necessary resplices. In accessing a splice tray, the technician should move as few installed fibres as possible. Moving fibres routed to the splice trays will increase the time required for the splicing functions as well as the probability of causing a failure within the system.

Each splice tray needs a sufficient amount of slack fibre stored around it to allow the tray to be easily moved between one and three metres from the splice panel. This ensures that the splice technician can do any work in a proper position and work environment. If the splice technician has to struggle to gain access to the service loop for the splices, the probability of the technician damaging another fibre is greatly increased, and the probability of the technician properly performing the assigned duties is reduced. In the splice trays, proper bend radius protection also needs to be observed. Aside from the points mentioned previously regarding fibre breakage and attenuation, a sharp bend within the splice tray near the splice will put added strain on the splice, increasing the possibility of a failure in the splice. Fusion splices have a higher probability of failing if added stress is put on the splice by a sharp bend before the splice.

Slack Storage

Most ODF systems encounter cable management problems in the storage of excess fibre cable. Since most singlemode connectors today are still factory-terminated to a patch cord of a predetermined length, there is always some excess fibre remaining after the connections have been made (see Figure 9). At some point during the life of the fibre network, it is likely that virtually every fibre circuit will be reconfigured. For most circuits, the duration between reconfigurations will be long, perhaps three to five years. During this time, these fibres need to be properly protected to ensure they are not damaged during day-to-day network operations. As the fibre's physical length and its potential exposure to damage and bend radius violations is greatest here, the slack storage system is perhaps the most critical element in terms of network reliability and reconfigurability. The slack storage system needs to provide flexible storage capacities, permanent bend radius protection, and easy access to individual fibres.

Slack storage systems come in many styles and configurations. Many systems involve coiling or wrapping fibres in open troughs or vertical cableways, which can increase the probability of bend radius violations and can make fibre access more difficult and time-consuming. The accessibility and thus the amount of time required to reconfigure the network is optimal in a system that maintains a continuous non-coiled or twisted routing of fibres.

As singlemode connectors become more reliable and easier to install in the field, some of the need for slack storage will disappear. It is also true, however, that terminating the connectors in the field, while reducing the initial ODF purchase price, will increase the installation cost and time. In existing offices, there will be a substantial base of installed fibre that will require storage for life, unless it is all replaced, an unlikely event due to high costs. The ODF system used should have an effective slack storage system that is easily incorporated or can be omitted, depending on the current network requirements and configuration.

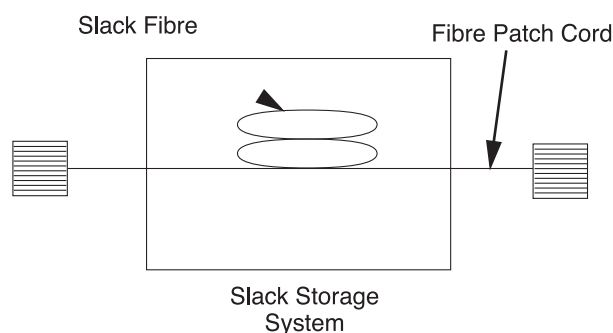

Figure 9. Slack storage systems

Technical Reference

Housing of Optical Equipment

As networks grow and technologies change, the ability to add optical splitters, Wavelength Division Multiplexers (WDM), optical switches and other opto-mechanical products to the ODF becomes more important. These devices should be easily, safely and economically integrated into the ODF.

One type of passive optical component, the optical splitter, is used in CATV networks for serving multiple nodes from one transmitter. This equipment allows fewer transmitters to be used in the network, greatly reducing system costs. Splitters are also used in local and long distance networks to allow non-intrusive network monitoring. This non-intrusive access allows an active signal to be monitored without interrupting or rerouting service to spare facilities, greatly reducing the time required to perform testing procedures and trouble-shooting (see Figure 10).

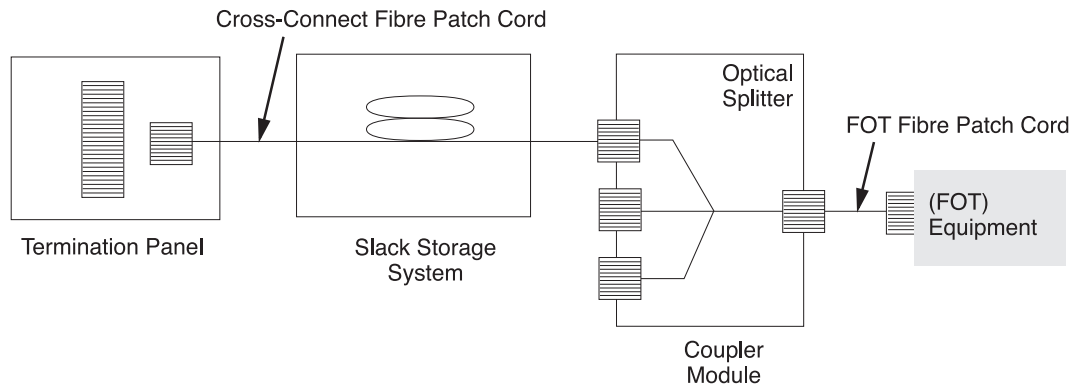

Figure 10. Incorporating optical couplers

WDMs are being used to increase the bandwidth of installed OSP fibre. For example, a 16-channel Dense Wavelength Division Multiplexer (DWDM) can increase a single fibre's bandwidth capacity 16-fold. WDMs can also be used in conjunction with Optical Time Domain Reflectometers (OTDR) to perform out-of-band testing (testing on one wavelength, operation on another) on active fibres. The use of OTDRs for out-of-band testing allows for very fast and efficient troubleshooting of fibre networks, as well as the ability to detect problems before they become service-affecting.

Optical switches can be incorporated into the ODF for use in redundant path switching, allowing for fast rerouting of critical networks onto spare facilities without having full redundancy built into the network.

Fibre optic test equipment can also be housed in the ODF to allow technicians easy access to equipment and test lines. Housing the test equipment in the ODF can reduce the time required for network trouble-shooting and restoration.

Where to locate optical components such as splitters and WDMs has been debated since their introduction. In the past, splitters and WDMs were often housed in splice trays or at the back of termination panels. But placing these components in splice trays increases the cost of installation, the time required to turn up service, and the probability of the device's failure, or damage to adjacent fibres. Today, deciding where to house optical components should be based on cable management and network flexibility.

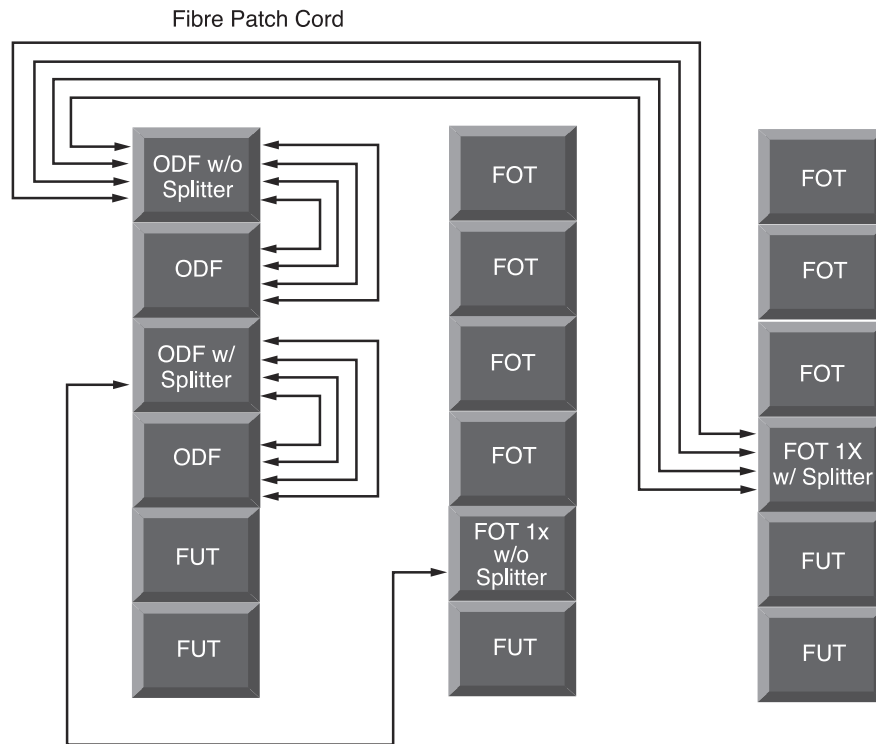

Figure 11. Deployment of optical components within the network

Take the case of a 1:5 optical splitter (see Figure 11). Housing the splitter at the transmitter requires that five fibres be routed to the ODF where there will be five terminations. Suppose that at a later time, this transmitter is replaced with one that uses a 1:12 splitter. In order to turn up that transmitter, seven patch cords have to be purchased and routed from the ODF to the transmitter located at the FOT. This is a costly and time-consuming operation that increases the fibre patch cord build-up in the raceway system between the ODF and the FOT equipment, making reconfiguration more difficult and increasing the risk of failure. Housing the splitter in the ODF, on the other hand, would require only one patch cord to be routed from the ODF to the FOT equipment at all times, no matter what the splitter configuration. Along with reducing the cost of initial network installation and the cost of reconfiguring the network, the reliability of the network will be improved.

For fibre networks incorporating DWDMs or Coarse Wavelength Division Multiplexers (CWDMs), the scenarios become more convoluted. The location of the DWDM or CWDM component depends on the type of system being implemented and how the office is set up. For example, an active 16-channel DWDM system will include signal reproduction at the proper wavelength, multiplexing, monitoring and regeneration (16 fibres in at any wavelength and one fibre out with the proper wavelengths multiplexed on it). This type of system will be housed in a single rack or cabinet with a single fibre being routed to the ODF. If, however, the system is one in which the transmitters, located at different points within the office, are operating at the proper wavelengths for multiplexing, then locating the DWDM multiplexer and demultiplexer passive components in the ODF may make sense.

Whatever the optical components, or the means by which they are incorporated into the fibre distribution system, they need to be properly protected. Bend radius protection and physical protection are the most important considerations for these devices. Following proper fibre cable management practices in incorporating these devices will reduce the cost of network installation, and network reconfigurations, while improving network reliability.

Technical Reference

Interconnect and Cross-Connect Applications

When configuring an ODF, one of the first considerations is the decision between interconnect and cross-connect architectures. As with the location of optical components, this decision has large implications for the network's future growth, reconfigurability, cost and reliability.

Interconnect

Interconnect involves the OSP cable being spliced to a pre-connectorised pigtail, which in turn is terminated to the back of a termination panel. The front of the panel allows access to the OSP fibre via a patch cord that is routed to the ODF directly from the FOT equipment (see Figure 12).

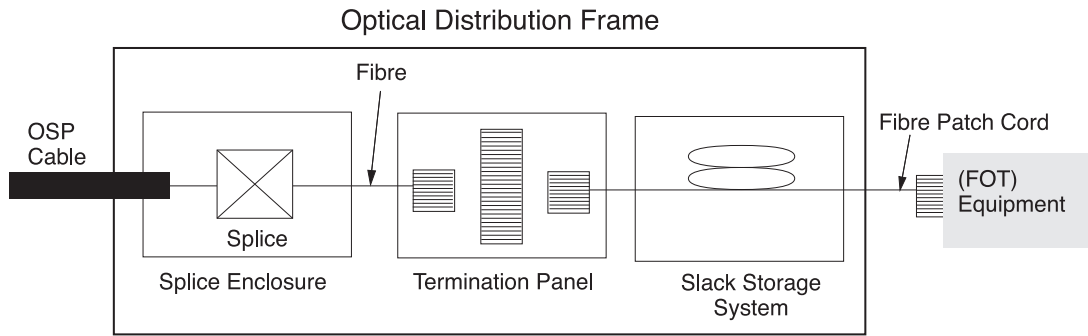

Figure 12. Interconnect signal flow

In interconnect, the FOT fibre does not have a dedicated port location. When the distance between the ODF and the FOT equipment rack is great, more than five metres, reconfiguring the network can be difficult. If the patch cord routed from the FOT and the ODF is too short to reach the far end of the lineup, another patch cord may have to be run between the ODF and the FOT. In large-office applications, this can take between 20 minutes and two weeks, depending on the layout of the office, the state of the cable raceway system, and the availability of a long enough patch cord (see Figure 13).

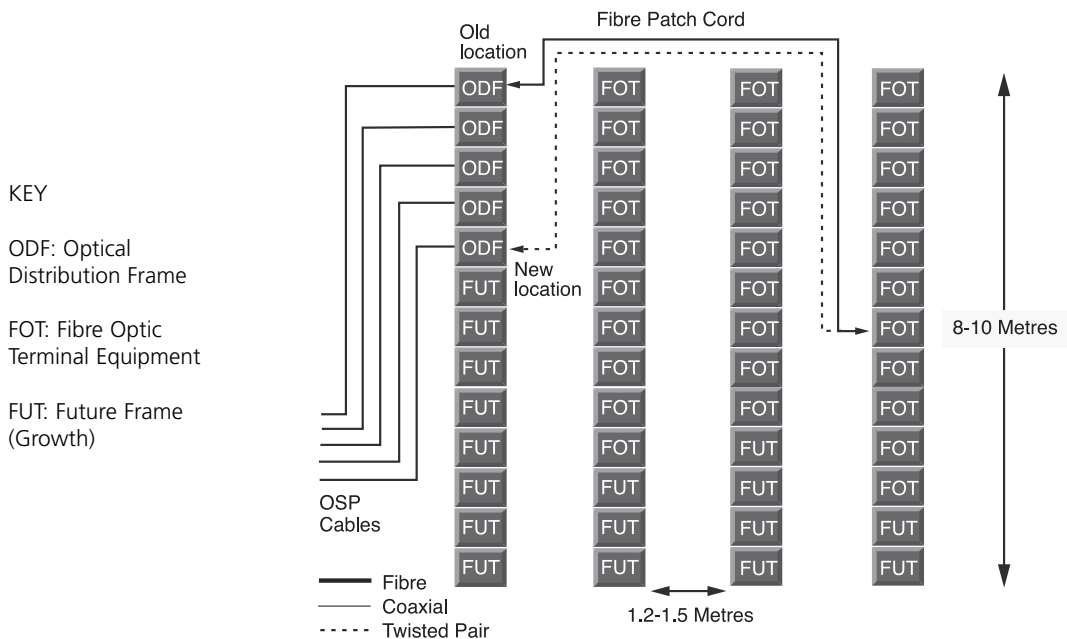

Figure 13. Interconnect network, architecture bay and fibre cabling layout

Technical Reference

Interconnect and Cross-Connect Applications

Also, any time a patch cord and corresponding fibre are moved, damage can occur. And if the patch cord is damaged during the rerouting, a new patch cord will have to be installed. These situations increase the time required to turn up new services or to reconfigure or restore existing services. This also increases network operating costs and can adversely affect customer service.

In interconnect systems, the slack storage system is generally not thoroughly considered, exposing large numbers of fibres to potential macrobending problems. Bend radius violations are common, and individual fibre access can be difficult. The introduction of field-terminated connectors would eliminate any storage issues, but it would also mean that any network reconfiguration would require a new patch cord to be run between the ODF and the FOT equipment. This would increase the congestion in the cable raceway between the frames, since the existing fibres would more than likely be left in place. The time required to reconfigure the network would also increase.

If no network reconfiguration is anticipated, an interconnect architecture can work; however, as network requirements change, the ability to reconfigure the network effectively and efficiently becomes more important. The fact that the FOT patch cords don't have a dedicated termination location makes patch cord labeling and record keeping both more difficult and more critical. Interconnect generally works best in low fibre count (less than 144 fibres) systems in which the distance between the ODF and the FOT equipment is short. Interconnect can also be more cost-efficient in initial installation, requiring a minimum amount of equipment and floor space. But the more a network changes, the more desirable a cross-connect architecture becomes.

Cross-Connect

A cross-connect ODF architecture provides a dedicated termination point for both the OSP fibres and the FOT equipment fibres. The OSP and FOT fibres are connected via a cross-connect patch cord routed between the two ports on the front of the ODF. This makes accessing the network elements much easier and more cost-efficient, and improves the long-term reliability of the installed fibre network (see Figure 14).

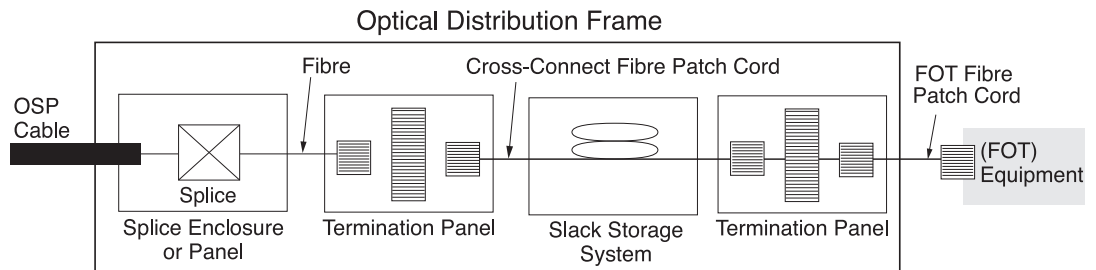

Figure 14. Cross-connect signal flow

A cross-connect configuration provides the greatest flexibility when it comes to future network reconfigurations. If reconfiguration is required, all the work is done from the front of the frame with a patch cord that is generally less than ten metres in length. If by chance this cross-connect patch cord is damaged during handling, another patch cord can be easily used to replace it. This is not the case within an interconnect network, where the patch cord being rerouted is connected to FOT equipment that may be on the other side of the office. Additionally, having proper slack storage for the cross-connect patch cord will ensure that the network can be quickly reconfigured without inducing attenuation on adjacent fibres.

An ODF system with a strong, flexible slack storage system will require only a few standard-length patch cords for use in cross-connect routings. Having fewer standard lengths of short patch cords required means that keeping such an emergency supply of cross-connect patch cords on hand is much easier and cheaper than keeping many different lengths in store.

Using a cross-connect architecture also allows multi-fibre cables to be routed between the FOT and ODF. Using multi-fibre cable assemblies can reduce the total amount of time required to install the fibre network. They also provide additional protection to the fibres being routed. At the same time, there are

Technical Reference

Interconnect and Cross-Connect Applications

operational and economic disadvantages to using multi-fibre cables, in both interconnect and cross-connect applications. For example, a rack of FOT equipment may handle equipment using a certain number of fibres in a multi-fibre bundle. If in four years, that equipment is obsolete and replaced with equipment that has fewer terminations in the same frame, the excess fibres will be very difficult to redeploy.

The key factor when considering cross-connect and interconnect architectures is the future reconfiguration capability of the method chosen. As the network grows and evolves, new and different technologies will be incorporated into the FOT equipment frames, and the existing equipment will become obsolete, or will be redeployed one or more times, until the oldest equipment is discarded or all fibres are used. This network reconfiguration could involve moving large amounts of electronics and many long patch cords, or reconfiguring short patch cords on the front of the frame (see Figure 15). The ease with which equipment is integrated into the network, and its potential effects on the installed network, will depend on the fibre cable management system. A cross-connect system with proper cable management features will allow the FOT equipment within the fibre network to be redistributed simply by rerouting patch cords on the front of the ODF.

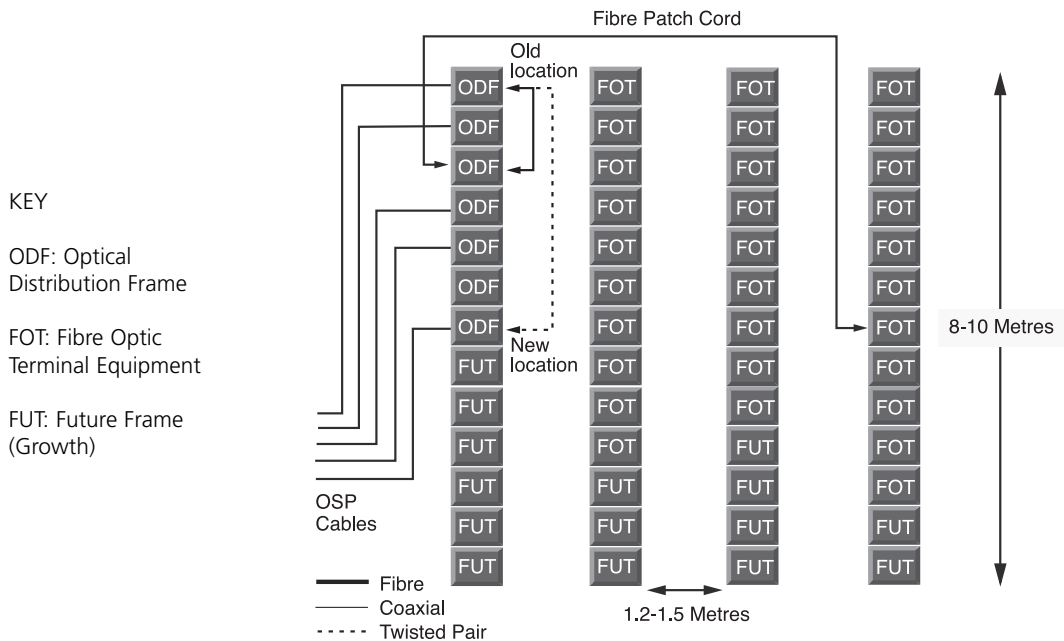

Figure 15. Cross-connect office and cable layout

Additionally, with cross-connect, both the OSP and FOT terminations have dedicated permanent locations on the ODF. This means that even if the record keeping for a cross-connect patch cord reconfiguration is not properly done, the technicians will always know where the equipment terminations and the OSP terminations are. This greatly reduces the time required to turn-up or restore services.

It is true that in initial installation a cross-connect system is about 40-percent more costly than a comparable interconnect system, because more equipment is needed. A cross-connect system will also require more floor space, from 30 to 100 percent more, depending on the configuration, since there are more terminations required in the ODF network (see Figure 16). In most OSP fibre networks, 50 percent of the fibres are spare or backup fibres (2:1 OSP:FOT ratio). These fibres are routed in the same sheath as the active fibre, but are used if the connector or the fibre at the far end is damaged. Reconfiguring the network to use the spare fibres is done at the ODF termination panel. Using cross-connect in this type of configuration will result in roughly a 35 percent increase in equipment costs, but will greatly improve network flexibility and the ability to reconfigure the network, while increasing network reliability.



Figure 16. ODF cross-connect configuration with 2:1 OSP:FOT ratio

The ODF system should be able to accept either interconnect or cross-connect, and allow both architectures within the same system. This flexibility allows a network that starts out using interconnect to migrate to cross-connect when and if it is needed, without having to replace existing equipment.

The ease with which the equipment can be redeployed and installed into the network depends largely on the ODF. In a full cross-connect ODF, in which the FOT equipment has a dedicated location in a termination panel, the existing equipment can be easily redeployed to a different OSP fibre via the cross-connect patch cord. The accessibility of this patch cord directly affects the cost of this network reconfiguration. The ODF should allow the entire cross-connect patch cord, including excess stored slack, to be easily removed for rerouting. Accessing this fibre should be done without causing additional attenuation on any installed active fibre.

Technical Reference

On-Frame and Off-Frame Splicing

The splicing of OSP fibres to connectorised pigtails, to allow termination panel access to the OSP fibre, can be done in two basic configurations: on-frame and off-frame.

On-frame splicing (see Figure 17) is performed within the confines of the ODF, whereas off-frame splicing is done away from the ODF, generally in or near the OSP cable vault.

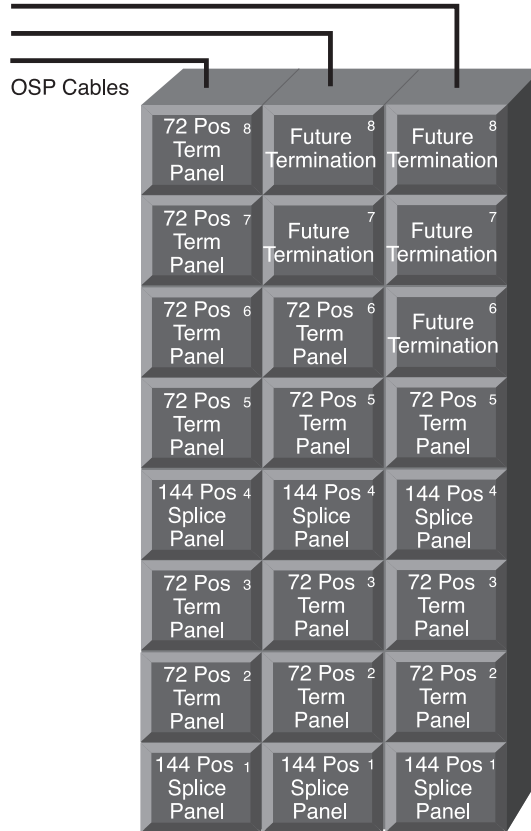

ODF with splicing and terminations located in central office.
(3) frames, total capacity: 1080 terminations.

Figure 17. On-frame splicing ODF layout

Original fibre networks incorporated on-frame splicing, since the fibre counts were very small. Even today, on-frame splicing can be a cost-effective solution for small and medium fibre count (less than 432 fibres) networks where future growth is limited. There are some drawbacks to this method, however. For one thing, the number of terminations in a single rack is reduced by the presence of the splice panels, so generally there are fewer than 432 terminations in a single frame.

One other drawback to on-frame splicing is the access to the ODF. Different organisational groups are usually responsible for splicing functions and cable installation. Having splicing on the fibre frame limits the functions that can be performed on the fibre network at the same time. For example, if the splicers are in the office splicing the OSP fibres to the pigtails, they will not want the operations group working on the frame at the same time trying to route patch cords. This conflict can result in delays in service turn-up as well as possible scheduling conflicts over accessing the ODF, resulting in an increase in the installation costs and an increase in the probability of failure in the network. When OSP fibre counts become larger and floor space is at a premium, off-frame splicing can provide many advantages over on-frame splicing.

Off-frame splicing (see Figure 18) involves splicing the OSP fibres to pigtails in a location away from the ODF, such as the cable vault. The splicing is done in a large-capacity splice frame or wall mount cabinet. Splice cabinets able to handle 864 splices are common. The link between the splice closure and the ODF is made via an Intrafacility Cable (IFC) that is connectorised on one end. The connectorised end is loaded into a termination panel. The loading of the connectorised IFC into the termination panel can

Technical Reference

On-Frame and Off-Frame Splicing

be done at the factory or in the field. However, experience has shown that factory loading reduces the overall cost of installation (including training costs) and the amount of time required for installation. Factory loading also increases network reliability. Termination panels with IFC assemblies are generally configured in 72 or 96 fibre counts.

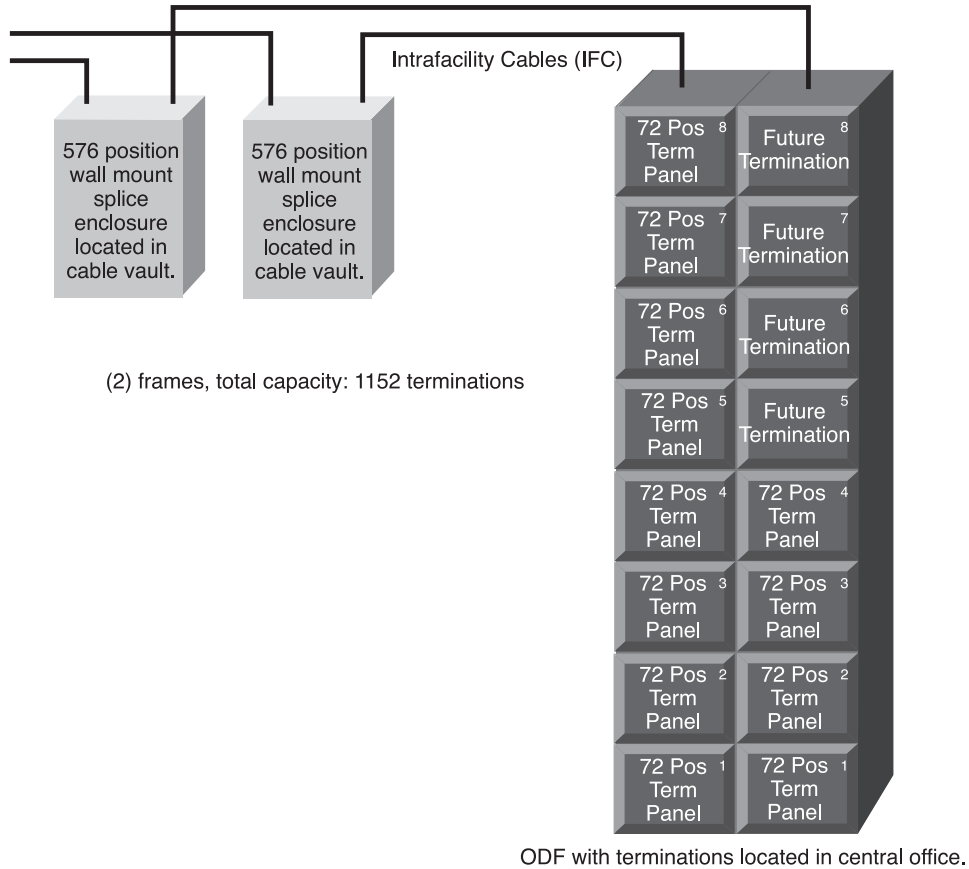

Figure 18. Off-frame splicing ODF layout

In large fibre count applications, with more than 432 incoming OSP fibres, splicing in a remote location can increase the termination density with the ODF to the point of reducing the number of racks required. This allows the floor space within the office to be utilised more cost-efficiently and provides room for future network growth.

Off-frame splicing can also improve flexibility in handling incoming OSP cables. For example, a service provider may have only 48-fibre OSP cables being routed through the network and may be using the most common rack mount splice panels, which come in multiples of 48-splice capacity (up to 192 splices per panel). These panels work well if the incoming OSP cables remain consistent in size through the life of the network. However, problems can arise when a variety of fibre cable sizes are deployed, with a mix of 24, 72, 96 and 144-fibre cables entering an office. In order to match these cables to a 48-splice capacity panel, the cable sub-units must be split between splice panels. The splitting of the sub-units between panels requires additional protection to shield the sub-units from damage. A dedicated splice facility, such as a wall mount splice enclosure accommodating 864 splices with any combination of OSP fibre counts, allows flexibility in the selection and routing of OSP cables.

Another advantage of off-frame splicing is that routing OSP cables through an office can be more difficult than routing IFC cables. OSP cables have a thicker, more rigid jacketing than IFC cables. OSP cables may also have metallic strength members that require special grounding not normally used on ODFs. In any case, the OSP cable's stiffness can make it very difficult to route through a central office or headend. IFC cable jacketing, on the other hand, is more flexible, but still rugged enough to be routed through an office without any additional protection.

Technical Reference

On-Frame and Off-Frame Splicing

There is a perception that off-frame splicing is more expensive than on-frame splicing, as it requires additional costs for equipment and IFC cable. In actuality, when looking at a system with more than 432 fibres in a cross-connect architecture, the price of a full ODF system with off-frame splicing will be equal to or slightly less than that of a full system with on-frame splicing. There are two reasons for this cost difference: the elimination of the splice panels from the ODF; and the reduction in the number of racks required. Reducing the number of racks increases the amount of equipment that can be incorporated into the installation, increasing the overall flexibility, and profitability, of the network.

Whatever splicing system is chosen, the decision needs to be based on long-term network requirements. A network in which on-frame splicing works well initially may require off-frame splicing in the future. The ODF system should have the flexibility to easily incorporate both on-frame and off-frame splicing. The operational impact of using the wrong splicing system can include running out of floor space, increasing network installation time and cost, and reducing long-term reliability.

Technical Reference

Racks, Cable Raceways and Density

Rack Size and Rear Access

The decision between 19 or 23-inch racks, ETSI racks or cabinets, as well as between front and rear ODF access or only front access, has implications for the operation and reliability of the ODF system. As a rule, the larger the rack and the greater the access, the better the cable management will be. An ODF in a 19-inch enclosed cabinet with no rear access will have far less accessibility and fibre cable management features than an ODF in a 23-inch open rack with front and rear access. This limited access space and lack of cable management features will have a direct impact on the flexibility and reconfigurability of the fibre network, as well as on the network's long-term reliability. Even though floor space requirements and existing practices may indicate a particular type of rack configuration, attention needs to be paid to the overall effect on fibre cable management.

Dedicated Cable Raceway System

As the fibres are routed from the ODF to the FOT equipment, they need to be protected. In order to provide proper protection and ensure future growth and reconfiguration capabilities, all fibres routed between the ODF and the FOT equipment should be placed in a dedicated cable raceway system. This system is generally located at the lower level of the auxiliary framing/ ladder racking structure. Locating the raceway system there makes access for installing and routing fibres easier. As the system is in an area of the office in which technician's activities are common, the cable raceway system needs to be durable and robust enough to handle day-to-day activities. For example, technicians installing copper or power cables on the ladder racking can come into contact with the system. If the system is not robust enough to withstand a technician accidentally putting his weight on it, the integrity of all the fibres in the system is in jeopardy. A durable, properly configured raceway system with suitable cable management, especially bend radius protection, helps improve network reliability and makes network installation and reconfiguration faster and more uniform.

Cable Raceway Congestion

Cable congestion is just like traffic congestion. Put too many cars at one time onto a small road and you have traffic problems. It becomes difficult to move from one point to another, and the probability of having an accident increases. The same basic rules apply to fibre congestion in an ODF's raceway system. If too many fibres are routed into a single trough, accessing an individual fibre becomes very difficult, and the probability of damaging a fibre increases. This can lead to decreased network reliability and an increase in the time it takes to reconfigure the network. Telcordia recommends that the fibre cable in any given horizontal raceway not exceed 50mm in depth. There are also formulas that can be used to calculate the maximum number of fibres that can be safely installed in a given cable trough. One such formula is given below:

$$\text{Raceway Capacity} = \frac{1 - 0.5}{\pi \times (\text{Cable OD}/2)^2} (\text{Raceway Width}) \times (\text{Jumper Pile Up})$$

For a 3mm fibre cable, for example, the formula shows that you can get 44 fibres per square inch of raceway space, or about seven fibres per square centimetre of raceway space. Thus a cable raceway that is 127mm wide can accommodate up to 440 3mm jacketed fibre cables. Following these rules ensures that the fibre cables are always accessible and helps maintain the network's long-term reliability.

Future Growth

The ODF system put into an office should be capable of handling the future requirements of the network. These requirements include the addition of more fibres as well as new products such as splitters, WDMs, optical switches and the like. The addition of any new panels, whether for splicing, termination, storage or other functions should not cause any interference with or movement of the installed fibres. This ensures that network reliability is maintained and also allows new services to be implemented quickly and cost-effectively. This ability to add equipment as needed allows the ODF to grow as the network requirements grow, thus reducing the initial installation cost of the network while reducing the risk of network failure.

Effect of High Density

Manufacturers are developing high-density ODFs to accommodate higher and higher numbers of terminations in a smaller and smaller area. While high termination density requires less floor space, strong consideration needs to be given to the overall cost of such increased density. A higher-density ODF does not necessarily correspond to a higher fibre count potential in the office. The focus needs to be on having a system with strong cable management features that is flexible enough to accommodate future growth, while allowing for easy access to the installed fibre network.

Specifying Fibre Cable Management Systems: Cost and Value

As a means of keeping operational costs down, service providers around the world are increasingly turning to systems integrators to install their networks. This practice allows the service provider's technicians to focus on operations and maintenance, rather than network installation. There is, however, an inherent risk in this practice. As the purchasing decision for the fibre cable management system moves from the service provider's engineering group to the systems integration prime contractor, the cable management features of the distribution system are generally not specified. What can happen, then, is the equipment installed may lack key features and functionalities. In light of the importance of proper cable management within the ODF, the service provider needs to specify the basic requirements for the cable management system. There are several industry-standard specifications that can assist service providers in writing specifications for their cable management systems. Two of these specifications are:

- Telcordia Generic Requirements for Fibre Distribution Frames GR-449-CORE, Issue 2, July 2003
- Network Equipment Building System (NEBS) Generic Equipment Requirements, TR-NWT-000063

Relative Cost and True Value of Fibre Cable Management

In looking at the initial purchase cost of the typical fibre cable management system in comparison to the overall cost of installing a complete network, one sees that the cable management system accounts for a small percentage of the overall network cost. In a US\$49M synchronous Digital Hierarchy (SDH) project involving SDH hardware, fibre cable management equipment, OSP fibre cables and full installation and turn-up, the ODF equipment may run only 1 to 2 percent of the overall network cost, depending on configuration and fibre count. This US\$49M cost does not include any twisted pair or coaxial equipment. When the fibre cable management system is viewed as part of the entire network, including the copper and coax portions, its cost drops to less than 0.1-percent of the total cost.

While the fibre cable management cost is small in relation to the overall system cost, it is the one area through which all the signals in the fibre network route, the one area in which the future flexibility and usability of the fibre network can be most affected. Yet even though the fibre cable management system's quality is critical to network reliability and network operations' cost-effectiveness, the sole consideration in many purchases is price. But initial cost is only one part of the total cost of ownership and doesn't give a true indication of the other factors that go into the real cost. A 15 percent difference in fibre cable management system price will result in a negligible savings in the overall network cost, but it could cost hundreds of thousands of dollars in lost revenue and higher operating expense.

The focus of the purchasing decision for the cable management system should be on getting the most cost-effective system that provides the best cable management, flexibility, and growth capabilities, that helps ensure the long-term reliability of the fibre network while allowing easy reconfigurations and keeping operating costs to a minimum.

Conclusion

As competition intensifies in telecommunications markets, low cost, high bandwidth, flexibility and reliability will be the hallmarks of successful service providers. Fibre is the obvious medium for networks with these characteristics. But providers will miss many of fibre's benefits unless they get the cable management right. Going with the cheapest approaches for fibre cable management can be "penny-wise and pound-foolish." It can mean dramatically higher long-term costs and lower reliability. On the other hand, strong fibre cable management systems with proper bend radius protection, well-defined cable routing paths, easy fibre access and physical protection will enable providers to reap the full benefits of fibre and operate a highly profitable network.